

## USE AND MAINTENANCE MANUAL SPARE PARTS

### SPIRAL MIXERS WITH FIXED BOWL

#### MODEL

M 80

M 80 PREMIUM

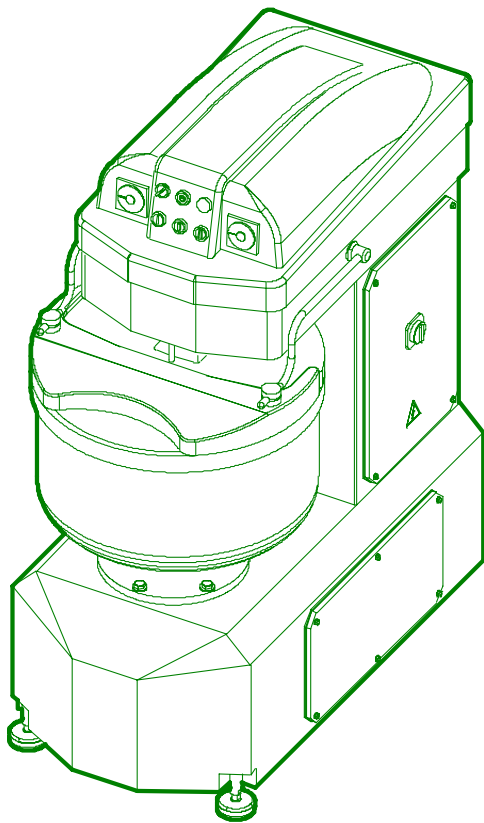

A MACHINE DESIGNED AND CONSTRUCTED  
 FOR MIXING BREAD AND PASTRY DOUGH

#### FOREWORD

- P.1 User, aim and use of the manual.....2
- P.2 Machine marking data.....2

#### SECTION A General information

- A.1 Warnings .....2
- A.2 General description of the machine .....2
  - A.2.1 Work environment .....2
  - A.2.2 Dismantling .....2
- A.3 Unacceptable conditions of use .....2
- A.4 Cleaning.....2
- A.5 Reference standards .....3
- A.6 Operators .....3

#### SECTION B Information regarding machine use

- B.1 Technical data.....3
- B.2 Transportation and handling .....3
- B.3 Installation – Preparation for commissioning....5
- B.4 Normal and safety shutoff .....5
- B.5 Control panel .....6

#### SECTION C Information regarding maintenance

- C.1 Maintenance .....7
- C.2 Adjusting belt tension for spiral rotation .....7
  - C.2.1 Model M80 .....7
  - C.2.2 Model M80 PREMIUM.....8
- C.3 Adjusting belt tension for bowl rotation .....9
- C.4 Wiring diagram for power supply.....10
- C.5 Wiring diagram for control panel.....11
- C.6 Spare parts list for 400 V system..... 12
- C.7 Spare parts list for control panel.....13

#### SECTION D Mechanical parts

- Table 1 Head group of model M - exploded view... 14
- List 1 Head group list of model M.....15
- Table 2 Head group of model M PREMIUM  
 -exploded view..... 16
- List 2 Head group list of model M PREMIUM..... 17
- List 3 Bowl group list..... 18
- Table 3 Bowl group - exploded view ..... 19
- Table 4 Machine structure - exploded view.....20
- List 4 Machine structure list.....21

### SPARE PARTS ENQUIRY

*Always mention:*

- Machine model
- Serial number
- No. of reference table
- ⇒ Position in the list of the spare part requested
- ⇒ Piece description
- ⇒ Quantity needed
- ⇒ Code

## FOREWORD

### P.1 USER, AIM AND USE OF MANUAL

This instructions booklet is directed to:

- the personnel in charge of the workshop and maintenance
- the personnel in charge of installation
- the user
- the personnel in charge of dismantling

The **user** must take care of the manual, ensuring that it is not damaged, and furthermore provide a place for it to be kept which is both safe yet easily accessible.

The **manual** is divided into four sections: one foreword and three sections regarding safety, use and maintenance.

- FOREWORD: The manufacturer's details and machine data, which must be quoted in all situations, are recorded in this section.
- SECTION A: Regards *safety regulations and information*.
- SECTION B: *Machine characteristics – operation – transportation – assembly of equipment* are described in this section.
- SECTION C: Includes information regarding *maintenance, lubrication and plant drawings*.

For further information, either contact the manufacturer directly or the authorised agent; always quote the details stamped on the machine plate.

### P.2 MACHINE MARKING DATA

	MODEL	_____
	SERIAL NUMBER	_____
	DATE OF MANUF.	_____
	VOLTAGE	_____
	FREQUENCY	_____
	PHASES	_____
	AMPS	_____

This booklet is the Instructions Manual for the machine referred to above and has been compiled in conformance with the EEC Directive 89/392, Enclosure I, paragraph 1.7.4.

## SECTION A: GENERAL INFORMATION

### A.1 WARNINGS

In order to ensure maximum working reliability, ESCHER MIXERS takes great care in the choice of materials and components to be used in the construction of its equipment, which is fully inspected and tested before consignment. The long term efficiency of the machine also depends on its correct use and the proper preventive maintenance as specified in the instructions described in this manual.

The manufacturer wishes to point out that:

- *Every part of this manual must be carefully read and fully understood before using or tampering with the machine.*

- *The machine must not be tampered with, altered or modified, even partially, and in particular, the protection guards must not be removed.*
- *The machine must not be used in conditions or for use other than those specified in this manual. The manufacturer shall not be held responsible for breakdowns, malfunctions or accidents caused by the non-observance of this rule.*

The EC plate is located on the lower rear part of the machine.

### A.2 GENERAL DESCRIPTION OF THE MACHINE

The machine has been designed and constructed for professional use with foodstuffs.

The aim of the mixer is to obtain a well-blended mixture for both bread dough and pastry.

The tables which include the technical data, use of the machine and command functions can be found below, in Chapter B.4.

#### A.2.1 WORK ENVIRONMENT

Acceptable work values for good machine performance:

- *Temperature:* from +5° to +40°C, with an average which must not be above 35°C in a 24 hour period.
- *Relative humidity:* between 30% and 95% (without condensation).

Provide opportunities and means for carrying out *cleaning and maintenance* operations.

Isolate the machine so that untrained personnel cannot access it.

Noise emission in the worst possible conditions is less than 70 dB.

#### A.2.2 DISMANTLING

In the event that the machine is to be scrapped, its parts must be disposed of *separately*, taking into consideration the different compositions of the various parts, and according to the law regulating the disposal of industrial waste.

*None of the components are classified as toxic-noxious products.*

### A.3 UNACCEPTABLE CONDITIONS OF USE

The obvious conditions in which to avoid using the machine could include:

- Load greater than the allowed amount.
- Tampering of the safety systems.
- Use of equipment that is not supplied with the machine, that is not suitable for handling food or that could scratch the surface of the bowl.
- Using the machine in unsuitable environments.

### A.4 CLEANING

As the machine is used for handling food, cleaning must be *thorough* and carried out *on a daily basis*.

Use only water together with a non-abrasive sponge and a plastic spatula to remove any residual incrustations.

The *area surrounding* the machine must be cleaned, and the machine must regularly be moved so that the *area under* the machine can also be cleaned.

When moving the machine disconnect the plug from the power outlet and raise the feet.

## A.5 REFERENCE STANDARDS

The model of the machine described in this manual is in compliance with Directive 89/392/EEC, with its amending directives and with reference to the following standards:

- UNI EN 292-1, UNI EN 292-2. *Basic concepts for machine safety and general design principles.*
- UNI EN 294 *Safety distances.*
- UNI EN 349 *Minimum distance to prevent crushing.*
- EN 60204-1 *Electrotechnical aspects.*
- EN 453 *Machines for the production of food products – Mixers.*

## A.6 OPERATORS

The machine has been designed and constructed for professional use. Therefore:

- The operator must be familiar with the *control panel* functions, the installed safety systems and regularly check their efficiency. He must be familiar with all possible *work cycles* and the *quantity of product* to use. He must *clean* the machine every day.
- Technician in charge of ordinary maintenance (see point C.1) can be one of the user's technicians who inspects the command and safety devices and regularly checks the condition of the belts.
- Technician in charge of extraordinary maintenance and repairs (see point C.1), while the machine is under warranty, must be *authorised by the manufacturer*.

Refer to the chapter on Maintenance (Sect. C).

## SECTION B: INFORMATION REGARDING MACHINE USE

### B.1 TECHNICAL DATA

MODEL	DOUGH CHARACTERISTICS			BOWL CHARACTERISTICS			MACHINE CHARACTERISTICS				MOTOR CAPACITY		SPEED		PACKAGED WEIGHT		
	max capacity	max flour	water*	volume	diameter	height from ground	length	width	height	weight	spiral I/II speed.	bowl	spiral I/II speed.	bowl	carton on pallet	wooden crate	wooden box
	kg	kg	l	l	mm	mm	mm	mm	mm	daN	kw	kw	rpm	rpm	daN	daN	daN
M 80	80	50	30	123	650	925	1146	678	1345	433	2.1 3.7	0.55	116 237	13	485	511	
M 80 PREMIUM	80	50	30	123	650	925	1146	678	1345	448	2.1 3.7	0.55	90 180	13	500	526	

\*) In this reference dough, the amount of water used is 60% with respect to the amount of flour.

PACKAGED DIMENSIONS [cm]			
	carton on pallet	wooden crate	wooden box
Length	138	130	130
Width	88	82	82
Height	172	158	158

### B.2 TRANSPORTATION AND HANDLING

To lift the machine *use suitable means and equipment*, and avoid oscillations.

The machine is off-centre, therefore take note of the precautions indicated on the *specifications sheet* affixed to the outside of the packaging. An example is reproduced below.

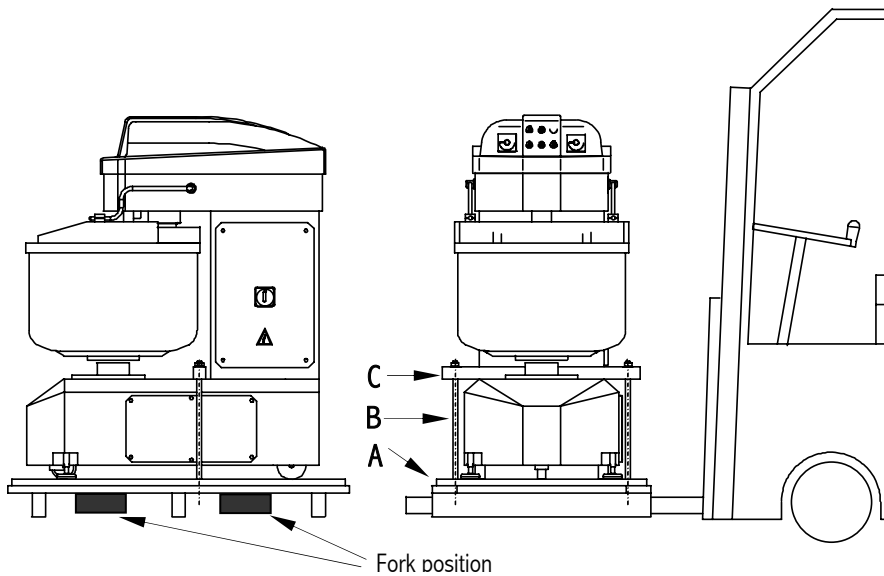

## 1. LIFTING THE PACKAGED MACHINE

The machine is transported on a wooden pallet **A**, secured by a cross bar **C**, and fastened to the pallet by means of two threaded rods **B**.

To lift by means of a pallet transfer unit or lift truck, insert the forks in the positions indicated in the figure.

*Before lifting, check the suitability of the equipment.*

### NOTE:

The material used for packaging, apart from the threaded rods and the bar, can be recycled or disposed of as urban waste.

## 2. LIFTING THE UNPACKAGED MACHINE

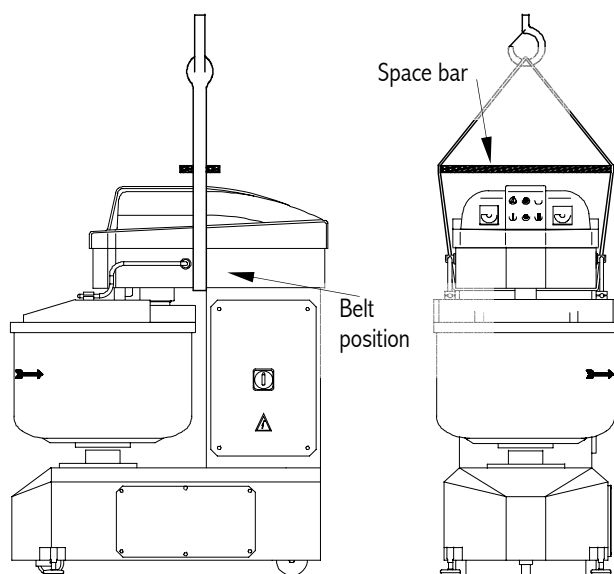

### By means of a belt

Positioned between the column and the end of the tool holder shaft, as shown in the figure.

It is advisable to use a *suitable space bar* (e.g. a wooden plank with a minimum section of 25x130 mm) in order to keep the belt away from the cover so that it is not damaged.

As the machine is decentred with respect to the point of suspension *the machine hangs in an off-balanced position*. In no way, however, does this effect the safety of the operators or the machine.

### NOTE:

*Avoid oscillations during this operation.*

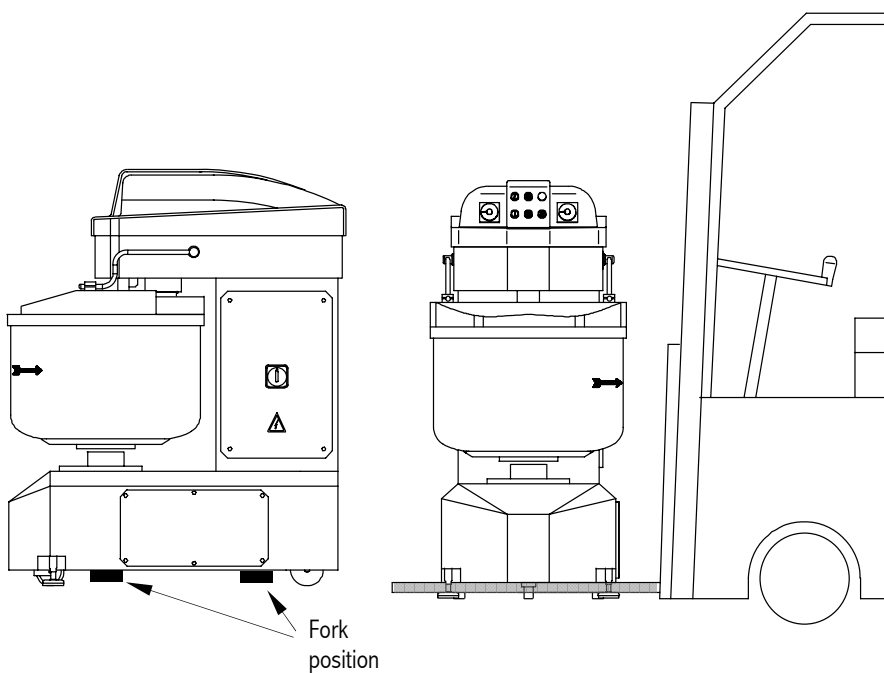

### By means of a lift truck

Insert the forks in the positions indicated. Lift carefully keeping the forks in a horizontal position.

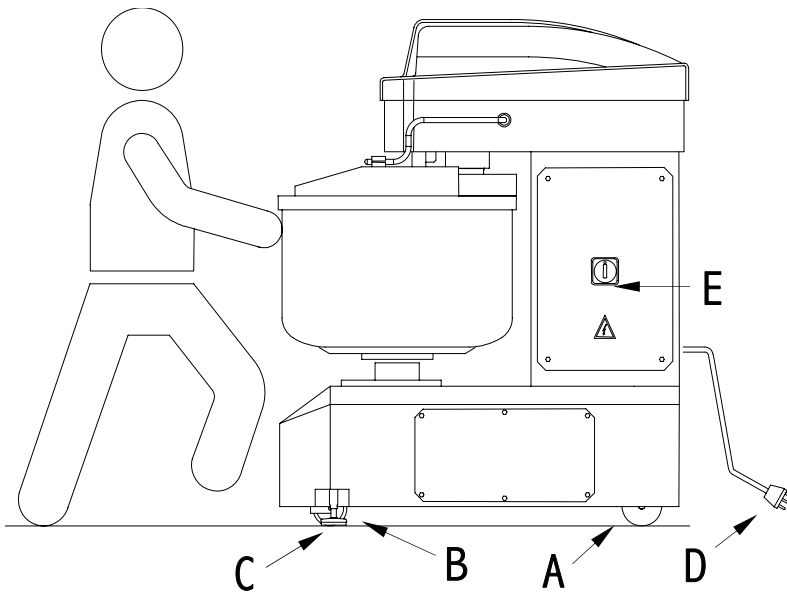

### 3. MOVING THE MACHINE BY HAND

The machine may need to be moved in order to clean the area under it.

#### To move the machine :

Tighten the threaded rod of the foot **C** which when it retracts allows the front pivoting wheel **B** to touch the floor. The other two points of support are the two rear fixed wheels **A**.

#### Caution:

- Disconnect the feed cable **D** before beginning the procedure described above.
- After returning the machine to its original position, ensure its stability by loosening the two threaded feet **C** thereby raising the front wheel **B** from the floor
- To power the control panel, activate the general switch **E**.

### B.3 INSTALLATION – PREPARATION FOR COMMISSIONING

- The machine must be positioned in an area which is suitable for working with foodstuffs and that can be thoroughly cleaned.
- It is not necessary to fasten the machine to the ground; however it must be levelled by adjusting the front feet which at the same time lifts the front wheel from the floor.
- Check that the electric line is correctly connected by means of an *approved plug*.
- Check all the commands and that the mobile guard protection microswitch is functioning correctly. *Adjustment is carried out by the manufacturer.* The user must contact the authorised technician if adjustment is required.
- Before commissioning, check the maximum quantities of the product to be loaded into the bowl, by consulting the tables in Chapter B.1 relevant to the model purchased.

### B.4 NORMAL AND SAFETY SHUTOFF

#### 1. NORMAL SHUTOFF

- *In manual mode:* Stop the machine by pressing the machine shutoff push button.
- *In automatic or semiautomatic mode:* The machine is automatically shutoff by the timers.

#### 2. SAFETY SHUTOFF

- The machine shuts-off whenever the mobile guard is lifted from the bowl.
- NOTE:  
*In all cases rotation is stopped, even if gradually, in less than 4 seconds.*

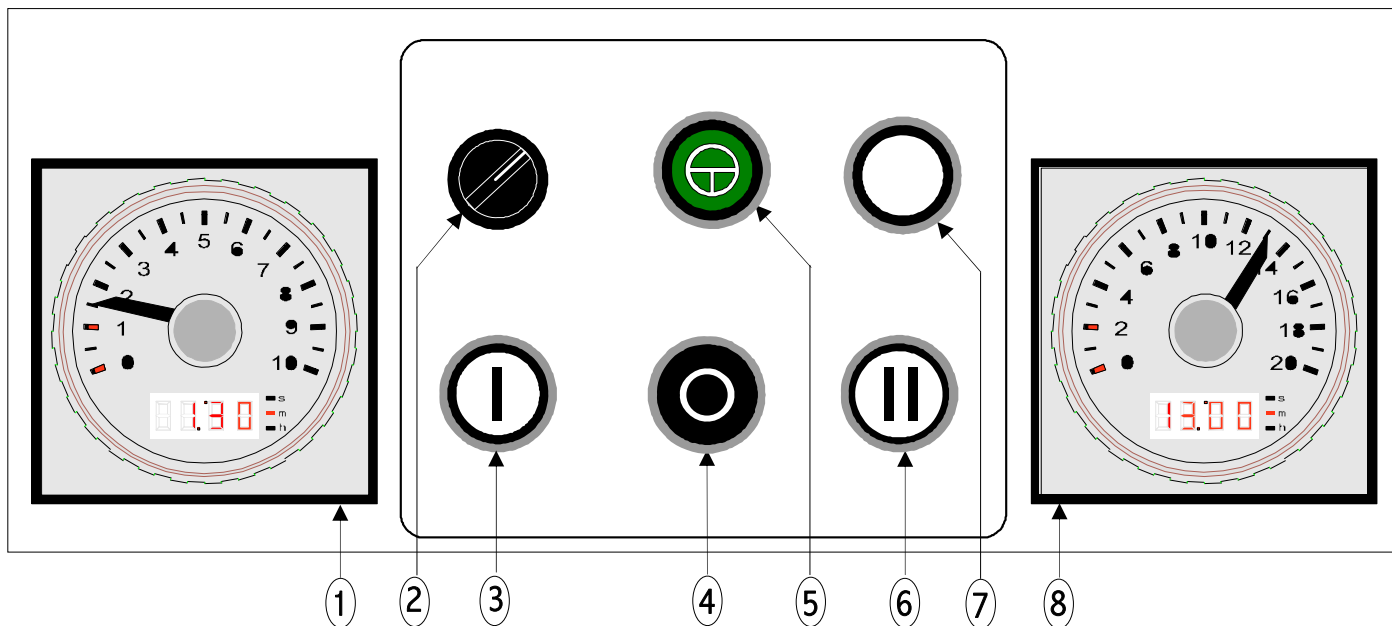

① *Timer for first spiral tool speed*

⑧ *Timer for second spiral tool speed*

When the pointer is below zero, (display unlit), the timed shutoff function is deactivated.

The LED, bottom right, when lit indicates whether the reading scale is in seconds (s), minutes (m) or hours (h). To change the scale consult the qualified technician.

② *Selector for bowl rotation direction in first speed.*

To reverse the rotation direction while in motion, turn the selector to the middle position, wait until the bowl stops rotating, then turn it to the other position.

*In second speed* there is only one rotation direction.

③ *Start push button for first spiral speed*

Does not function with the bowl cover open.

It permits three types of functions:

- MANUAL WORK MODE IN FIRST SPEED  
(Timers 1 and 8 deactivated)  
Shutoff by pressing stop push button 4.
- SEMIAUTOMATIC WORK MODE IN FIRST SPEED  
(Timer 1 activated, 8 deactivated)  
Shutoff is controlled by timer 1.
- AUTOMATIC WORK CYCLE  
(Timers 1 and 8 activated)  
The following sequence is carried out automatically:
  1. Timed work phase in first speed.
  2. Bowl stops for 2 seconds.
  3. Timed work phase in second speed.
  4. Automatic machine shutoff.

④ *Machine stop push button*

Interrupts all modes of rotation.

⑤ *Bowl jog rotation command in first speed*

Also functions with bowl cover open.

When the push button is released the bowl stops rotating.

⑥ *Start button for second spiral speed*

Does not function with the bowl cover open.

It permits two types of functions:

1. MANUAL WORK MODE IN SECOND SPEED  
(Timer 8 deactivated)  
Shutoff by pressing stop push button 4.
2. SEMIAUTOMATIC WORK MODE IN SECOND SPEED  
(Timer 8 activated)  
Shutoff is automatically controlled by timer 8.

⑦ *Power indicator*

When lit, it indicates that the electrical board is powered.

**NOTE**

If the cover is lifted while the machine is running, the machine shuts off, but the timers memorise the actual time reached. Once the cover has been closed again and the start buttons 3 or 6 pressed, the machine restarts and the timers permit the rest of the work cycle to be completed.

This memory is not stored if the machine is shut off by means of stop push button 4.

## SECTION C: INFORMATION REGARDING MAINTENANCE

### C.1 MAINTENANCE

#### 1. ORDINARY: Includes:

- Daily cleaning
- Checking the belt tension ( monthly)  
See chapter C.2 for operative methods.
- Checking the correct functioning of commands and safety devices (every time it is turned on).

#### 2. EXTRAORDINARY

This can be considered a *preventive operation* as well as an intervention in the event of *malfunctions and/or breakages*. These operations must be carried out by personnel *authorised by the manufacturer* or by one of his direct resellers. In the event that the user has specially trained personnel at his disposal, once the warranty has expired, he can request the manufacturer provide him with more detailed drawings and lists, as well as exploded views of the mechanical parts. In this case the user *is responsible for any damage* caused to persons and/or the machine.  
After 2000 working hours: it is advisable to have a technician inspect the bearings and the other transmission parts.

### C.2 ADJUSTING BELT TENSION FOR SPIRAL ROTATION

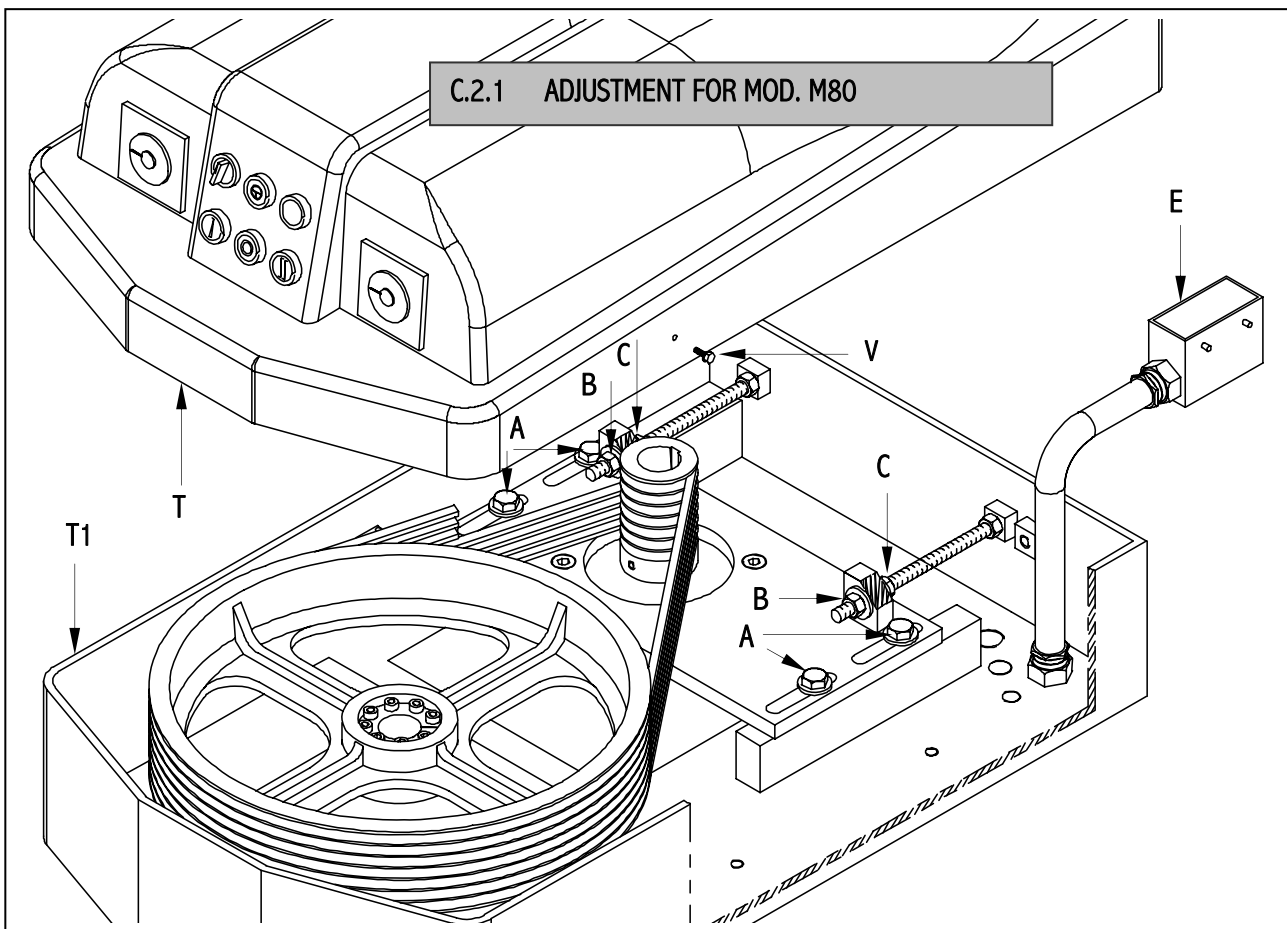

The belt tension must be adjusted if, during a work cycle, the operator notices a slowing down in the rotation of the spiral tool.

1. Remove the three side screws **V** which secure the head guard **T**.
2. Lift the head guard **T** and disconnect the connector **E**.
3. Loosen the 4 screws **A** which secure the motor support plate (without completely unscrewing them).
4. If necessary replace the belts:
  - Loosen the two nuts **B**
  - Tighten the two nuts **C** (in order to loosen the belts) and remove them.

#### 5. If necessary adjust the belt tension:

- To increase the tension:  
Loosen the two nuts **C**.  
Tighten the two nuts **B**.
  - To decrease the tension:  
Loosen the two nuts **B**.  
Tighten the two nuts **C**.
6. Tighten the four screws **A** which secure the motor support.
  7. Reconnect the connector **E**.
  8. Put the protection guard **T** back into its correct position with regard to the head **T1**.
  9. Tighten the three screws **V**.

## C.2.2 ADJUSTMENT FOR MOD. M80 PREMIUM

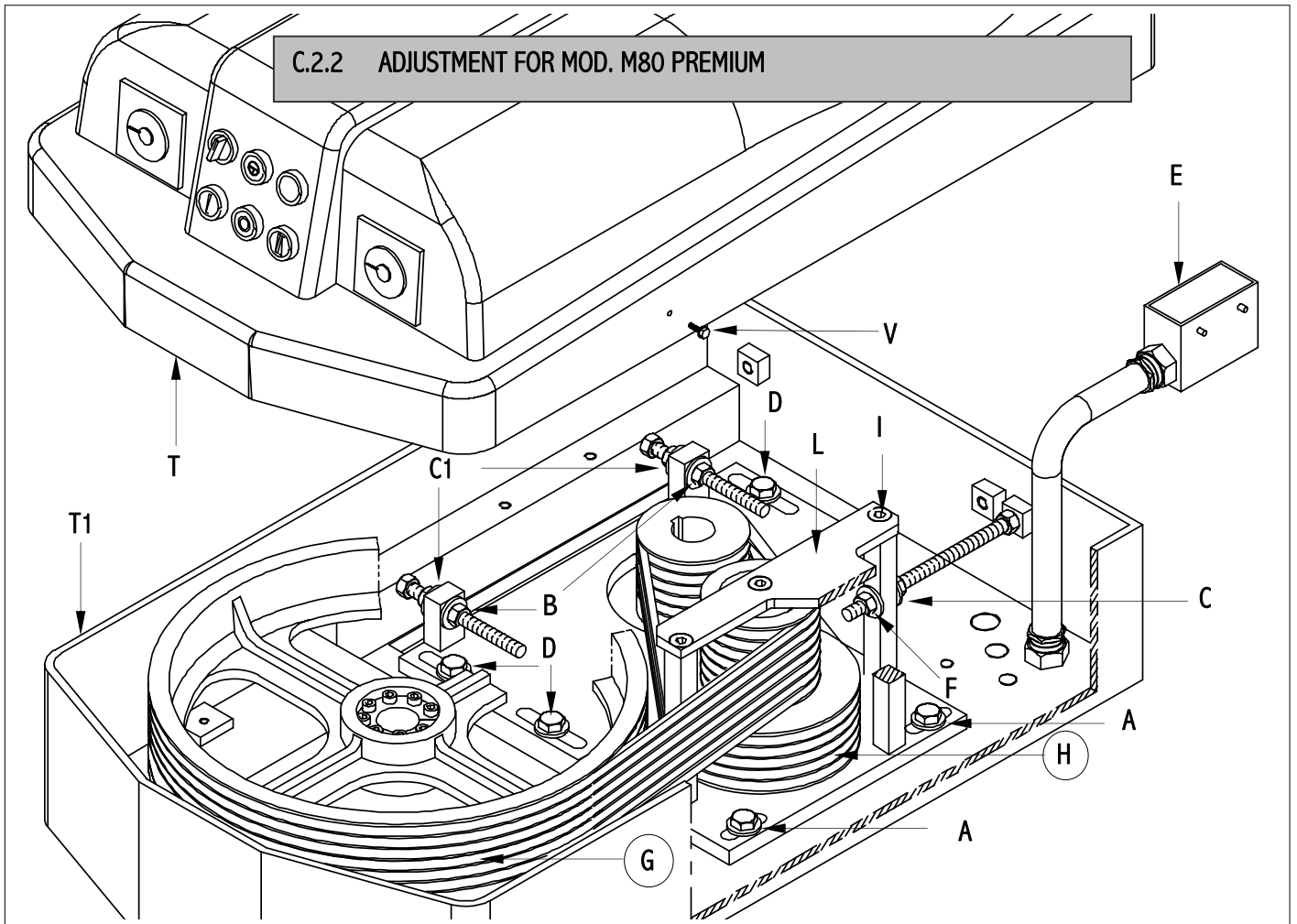

The belt tension must be adjusted if, during a work cycle, the operator notices a slowing down in the rotation of the spiral tool.

1. Remove the three side screws **V** which secure the guard.
2. Lift the head guard **T** and disconnect the connector **E**.
3. Loosen nut **C** and the two nuts **C1**, to allow movement of both the transmission pulley support and the motor support.
4. Loosen the 4 screws **D** which support the spiral motor (without completely removing them).
5. Loosen the four screws **A** of the transmission pulley support ( without completely removing them).
6. If the belts need to be replaced, proceed as follows:
  - Loosen the two nuts **B**.
  - Loosen nut **F**.
  - Remove the upper transmission plate **L** by loosening the 4 screws **I**.

Now the belts are loose and they can be replaced. Before replacing them ensure that the new belts have the same characteristics as the original ones.  
Firstly remove belts **G** and then belts **H**.  
Replace belts **H** and then belts **G**.

  - Reposition the upper transmission plate **L** and secure it by means of the four screws **I**.
7. If necessary adjust the tension of belts **G**:
  - To *decrease* the tension, loosen the nut and tighten **C**.
  - To *increase* the tension, tighten nut **F** and loosen **C**.
8. Secure the transmission plate by means of the four screws **A**.
9. Tighten the nut **C**.
10. If necessary adjust the tension of the belts **H**:
  - To decrease the tension, loosen nut **B** and tighten **C1**
  - To increase the tension, tighten nut **B** and loosen **C1**
11. Secure the motor plate by means of the four screws **D**.
12. Tighten the two nuts **C1**.
13. Reconnect the connector **E**.
14. Put the guard **T** back in its correct closed position with respect to the head **T1**.
15. Tighten the three side screws **V**.

### C3 ADJUSTING THE BELT TENSION FOR BOWL ROTATION

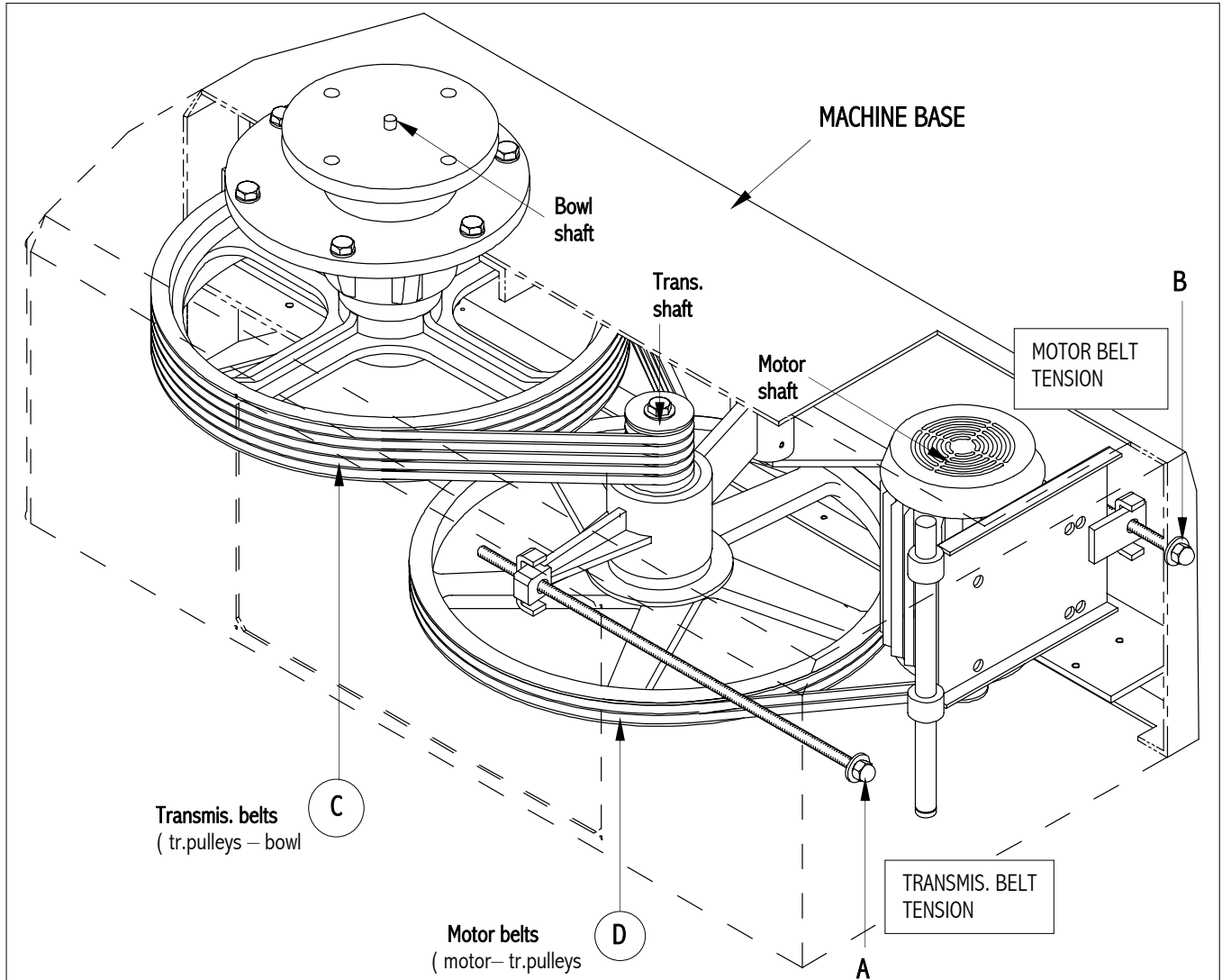

The belt tension must be adjusted if, during a work cycle, the operator notices a slowing down in the rotation of the bowl.

1. To increase the tension of the transmission belts C:  
Use a wrench to rotate nut **A** in a clockwise direction.
2. To increase the tension of the motor belts D:  
Use a wrench to rotate nut **B** in a clockwise direction.
3. To replace the belts:  
*The belt compartment can be accessed by removing the side door.*
  - Rotate nut **B** in an anticlockwise direction
  - Rotate nut **A** in an anticlockwise direction

Note: Ensure that the new belts have the same characteristics as the previous ones.

# C4 WIRING DIAGRAM FOR POWER SUPPLY

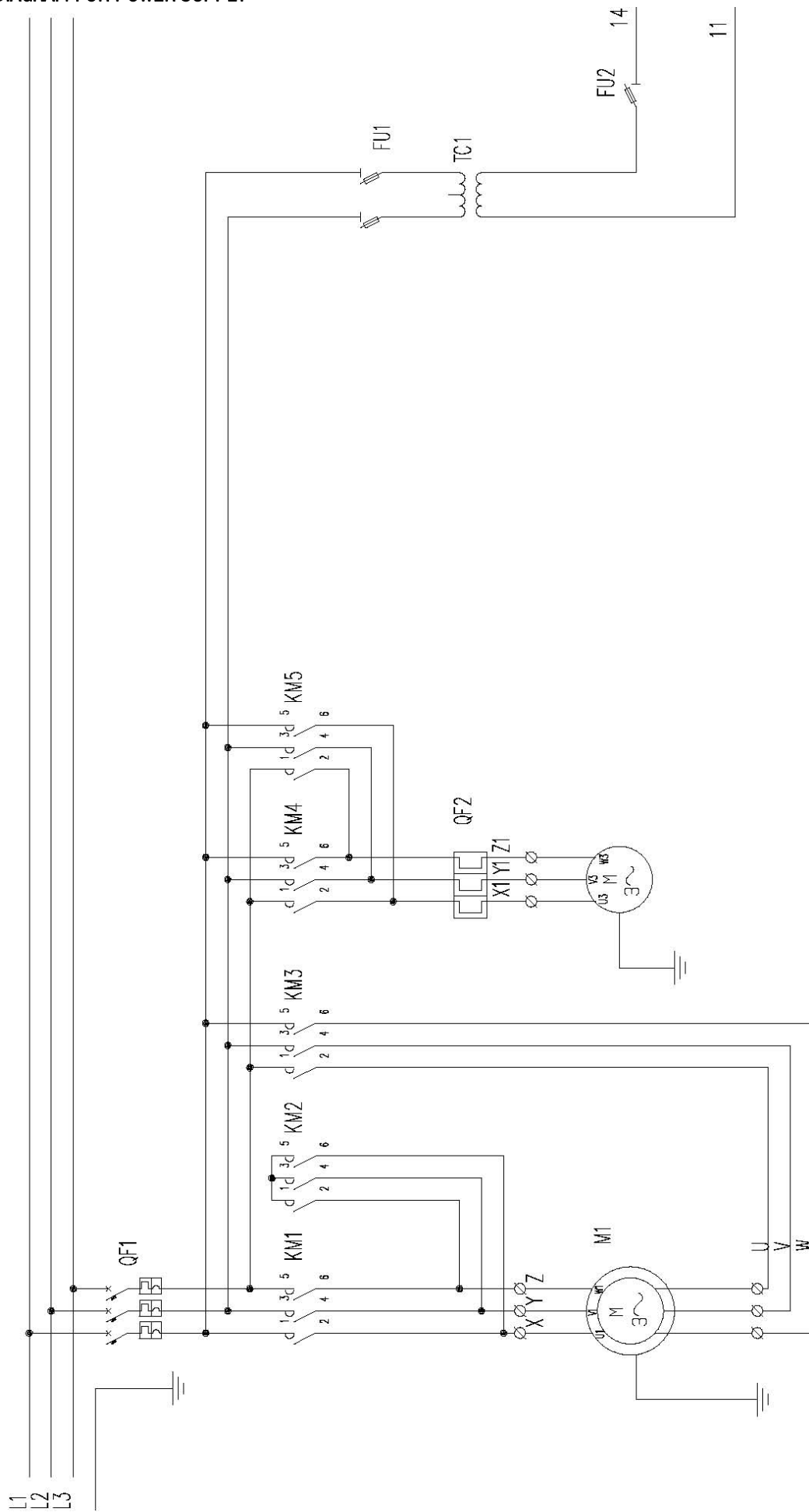



C6 Spare parts list for 400 V 50-60 Hz system

ID	DESCRIPTION	MANUFACTURER	CODE	Q.TY
M1	SPIRAL TOOL MOTOR 132 B14 4/8 poles 3/5.2 KW		E00305	1
M2	BOWL MOTOR 80 B3 6 poles 0,55 KW		E00000	1
TC1	TRANSFORMER	ITALWEBER	160VA 0.230.400.420 12.0.24 CE	1
KM1	CONTACTOR	MOLLER	DILM9-01	1
		MOLLER	DILA-XHI31	1
KM2	CONTACTOR	MOLLER	DILM7-01	1
		MOLLER	DILA-XHI31	1
KM3	CONTACTOR	MOLLER	DILM12-01	1
KM4	CONTACTOR	MOLLER	DILM7-01	1
KM5	CONTACTOR	MOLLER	DILM7-01	1
	KIT CONNECTION	MOLLER	DILM12-XSL	1
	KIT CONNECTION	MOLLER	DILM12-XRL	1
QF1	MAGNETO THERMAL	MOLLER	PKZM0-20	1
	HANDLE CONTROL	MOLLER	PKZ0-XRH	1
QF2	THERMAL	MOLLER	ZB12-2.4	1
FU1	FUSE HOLDER	LEGRAND	PCH 1 10x38	1
	FUSE	LEGRAND	2A GL	2
	FUSE HOLDER	LEGRAND	PCH 1 10x38	1
	FUSE	LEGRAND	2A GL	2
FU2	FUSE HOLDER	LEGRAND	PCH 1 10x38	1
	FUSE	LEGRAND	10A GL	2
	GROUND CONNECTING TERMINALS 4 mm <sup>2</sup>	CABUR	TO430	5
	CONNECTING TERMINALS 4 mm <sup>2</sup>	CABUR	CBC04	14
SQ1	LIMIT SWITCH	TELEMECANIQUE	XCKP102	1
J1	CONNECTOR 24P/F	WEIDMULLER	24P	1

C7 Spare parts list for control panel

ID	DESCRIPTION	MANUFACTURER	CODE	Q.TY
J1	CONNECTOR 24P/M	WEIDMULLER	2P4	1
SB1	EMERGENCY PUSH BUTTON	MOLLER	M22-PVT	1
		MOLLER	M22-A	1
		MOLLER	M22-K01	1
SB2	1 <sup>ST</sup> SPEED PUSH BUTTON	MOLLER	M22-DL-W-X1	1
		MOLLER	M22-A	1
		MOLLER	M22-K10	1
SB3	2 <sup>ND</sup> SPEED PUSH BUTTON	MOLLER	M22-DL-X	1
		MOLLER	M22-A	1
		MOLLER	M22-K10	1
		MOLLER	M22-K01	2
		MOLLER	M22-XDL-W-X2	1
SB4	JOG BOWL PUSH BUTTON	MOLLER	M22-D-X	1
		MOLLER	M22-XD-S-X11	1
		MOLLER	M22-A	1
		MOLLER	M22-K10	
SA1	BOWL SELECTOR	MOLLER	M22-WRK3	1
		MOLLER	M22-A	1
		MOLLER	M22-K10	2
HL1	POWER ON LIGHT	MOLLER	M22-L-W	1
		MOLLER	M22-A	1
		MOLLER	M22-LED-G	1
KT1	1 <sup>ST</sup> SPEED TIMER	SITEC	D01 SC.10	1
	SOCKET	CDC	AZ511	1
KT2	2 <sup>ND</sup> SPEED TIMER	SITEC	D01 SC.20	1
	SOCKET	CDC	AZ511	1

**Table 1: Head group of model M**

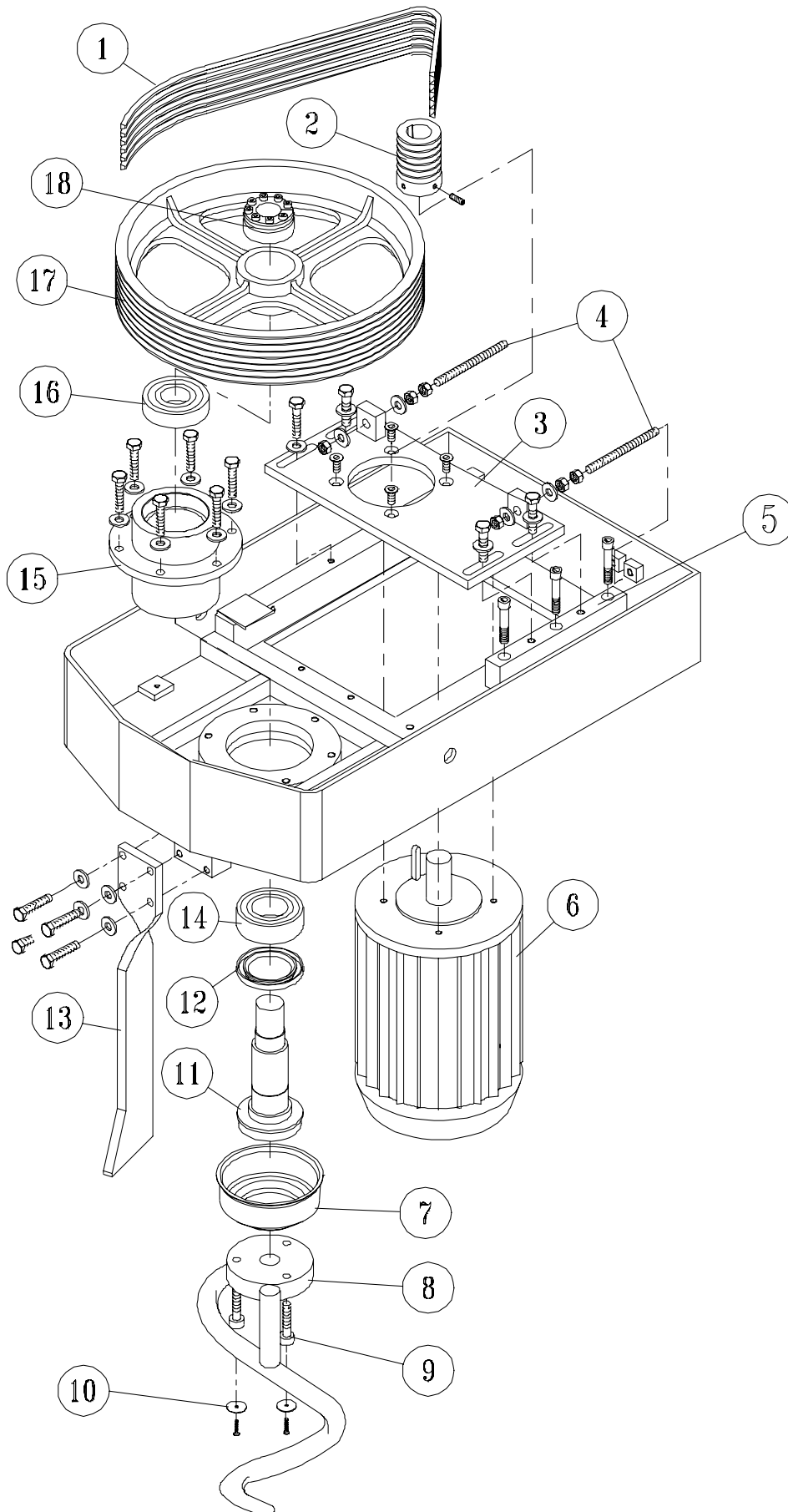

**List 1: Head group of model M**

<b>POS.</b>	<b>DESCRIPTION</b>	<b>Qty</b>	<b>CODE</b>
1	Belt SPZ 1587	5	C01211
2	Motor pulley	1	D11116
3	Spiral motor slide	1	D13101
4	Tie rod M12	2	C02914
5	Motor support	1	D04200
6	Motor	1	*
7	Sump	1	D08201
8	Spiral	1	D12214
9	Screw	3	D15000
10	Screw cover	3	D07500
11	Spiral shaft	1	D01100
12	MIM ring 65/100x12	1	C11900
13	Column with foot	1	D12100
	Column without foot	1	D12103
14	Bearing 3211	1	C00100
15	Spiral shaft support	1	D04002
16	Bearing 6310 2RS	1	C00004
17	Pulley	1	D11100
18	Locking assembly	1	C01301

\* see wiring diagrams

**Table 2: Head group of model M PREMIUM**

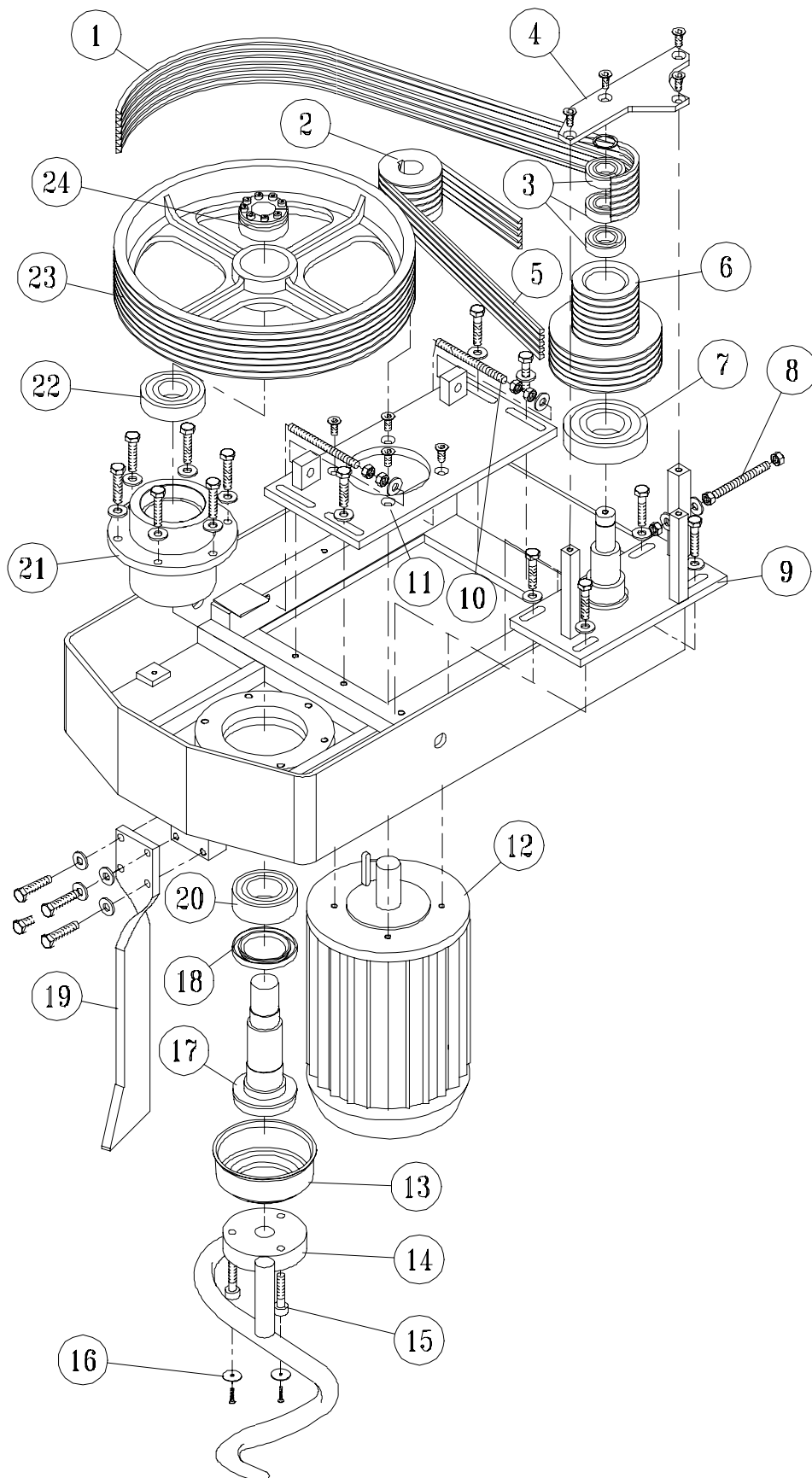

**List 2: Head group of model M PREMIUM**

<b>POS.</b>	<b>DESCRIPTION</b>	<b>Qty</b>	<b>CODE</b>
1	Belt SPZ 1587	5	C01211
2	Pulley 50 Hz	1	D11119
	Pulley 60 Hz	1	D11120
3	Bearing 62206 2RS	3	C00001
4	Reinforcing plate	1	D13000
5	Belt SPZ 862 (50 Hz)	4	C01203
	Belt SPZ (60 Hz)	4	
6	Transmission pulley	1	D11111
7	Bearing 6310 2RS	1	C00004
8	Tie rod M12	1	C02913
9	Transmission support	1	D04600
10	Screw TE UNI 5739 M12x130	2	C02012
11	Spiral motor slide	1	D13101
12	Motor	1	*
13	Sump	1	D08201
14	Spiral	1	D12214
15	Screw	3	D15000
16	Screw cover	3	D07500
17	Spiral shaft	1	D01100
18	MIM ring 65/100x12	1	C11900
19	Column with foot	1	D12100
	Column without foot	1	D12103
20	Bearing 3211	1	C00100
21	Spiral shaft support		D04002
22	Bearing 6310 2RS	1	C00004
23	Pulley	1	D11100
24	Locking assembly	1	C01301

\*) see wiring diagrams



**Table 3: Bowl group – exploded view**

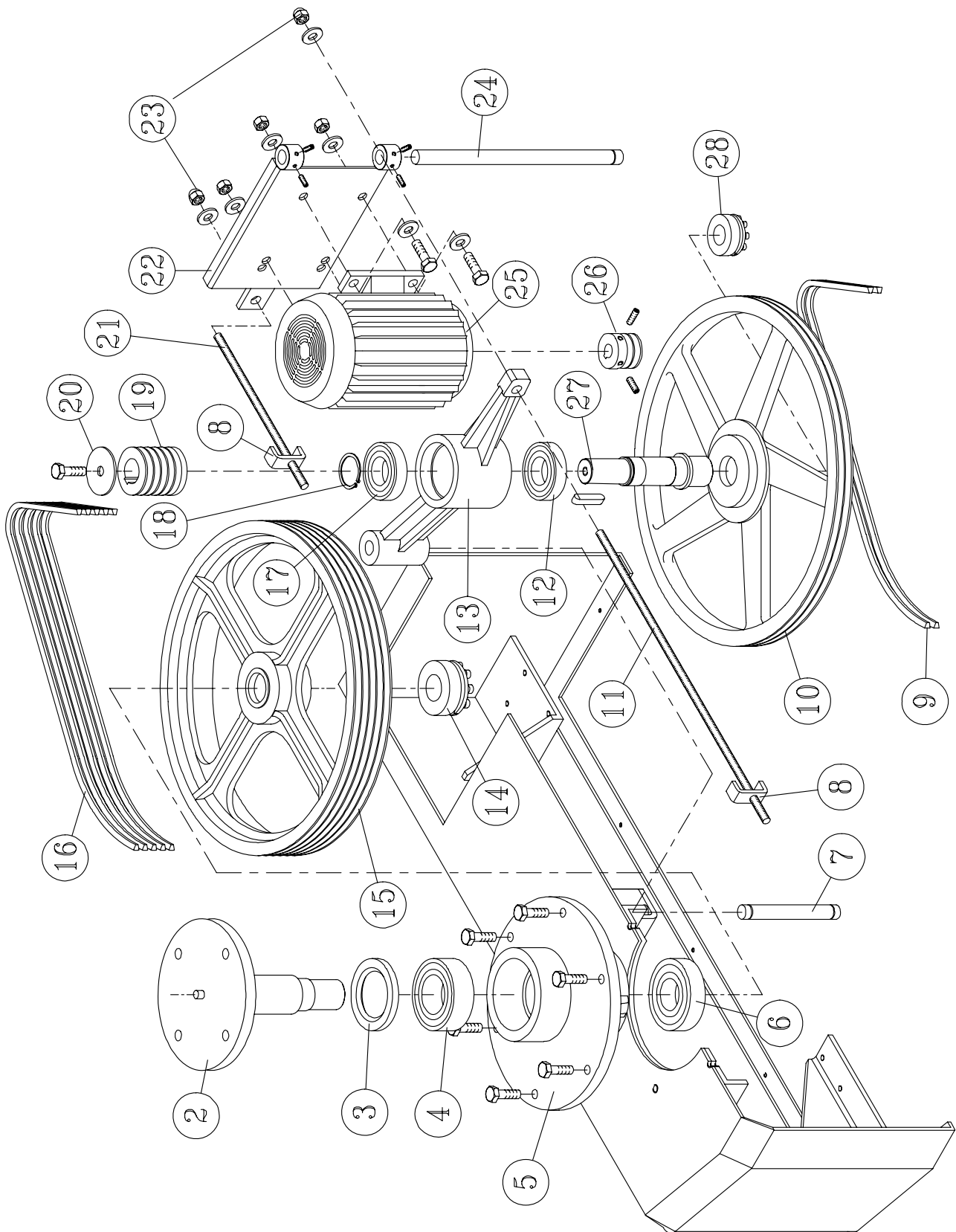

**Table 4: Machine structure – exploded view**

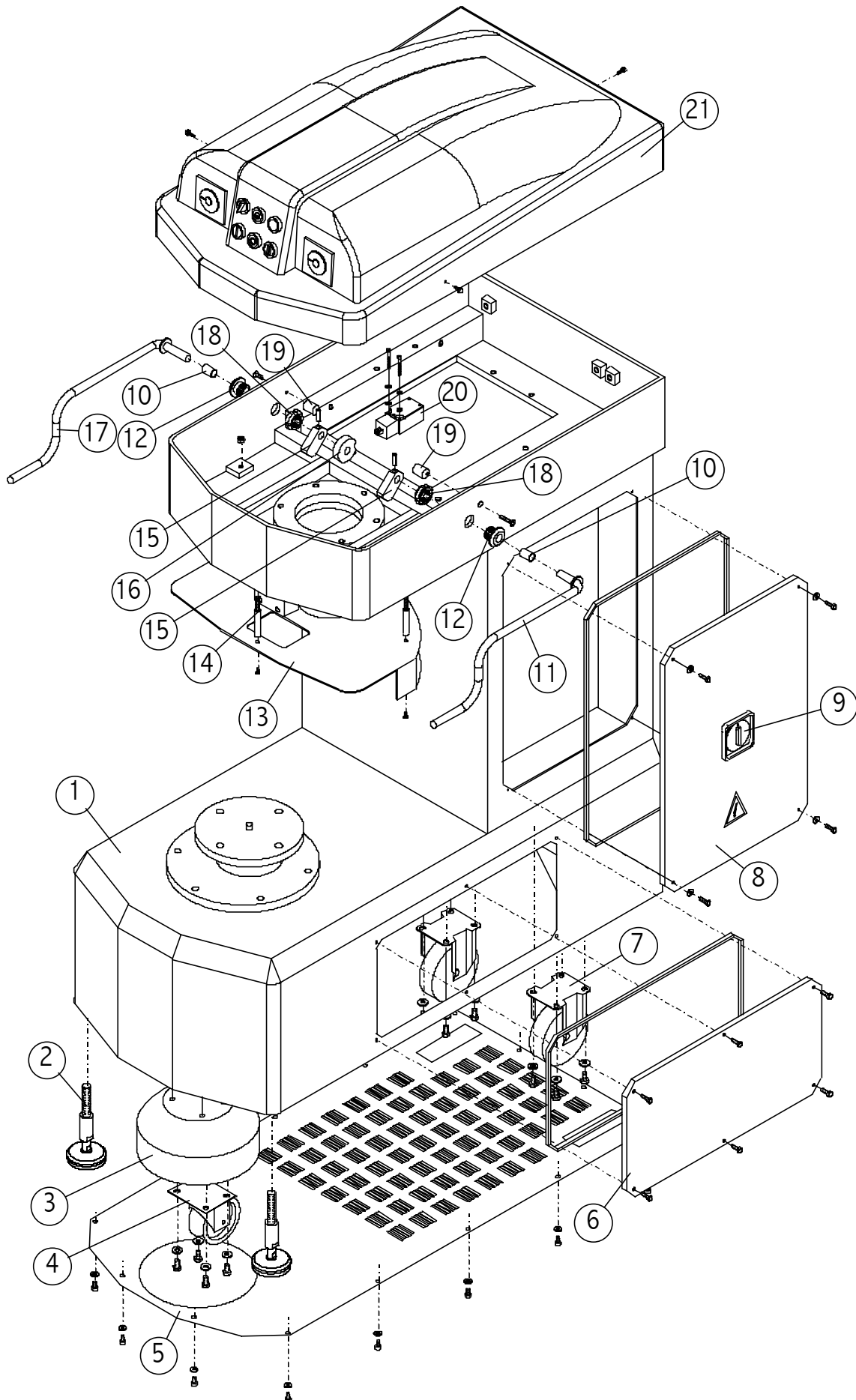

**List 4: Machine structure**

<b>POS.</b>	<b>DESCRIPTION</b>	<b>Qty</b>	<b>CODE</b>
1	Body	1	D03000
2	Foot	2	C01000
3	Wheel closing casing	1	D08200
4	Caster	1	C01400
5	Mouse protection grid	1	D07400
6	Base door	1	D07000
7	Rear wheel	2	C01401
8	Electric system door	1	D07001
9	Main switch	1	*
10	Bush DU151725	2	C00201
11	RH arm	1	D04500
12	Arm/head coupling bush	2	D05002
13	Fixed guard	1	D07329
14	Fixed guard spacer	3	D01302
15	Guard stop plate	2	D04401
16	Microswitch cam	1	D06000
17	Left arm	1	D04501
18	Ring nut GUK G25	2	C01100
19	Cam bush	2	D05003
20	Safety microswitch	1	*
21	Head cover	1	D08001

\*see wiring diagrams