

ORWAK

3110



Reservdelista
Spare part list
Ersatzteilliste
Liste de pièces détachées
Lista de repuestos



3110
INNEHÅLLSFÖRTECKNING / TABLE OF CONTENTS /
INHALTSVERZEICHNIS / TABLE DES MATIERES /
CONTENIDO



Svenska	English	Deutsch	Français	Español	
VIKTIGT!	NOTE!	WICHTIG!	IMPORTANT!	IMPORTANTE!	3
Behållare	Chamber	Behälter	Chambre	Cámara	4-5
Pressenhet	Press unit	Presseinheit	Unité de compactage	Unidad de compaction	6-7
Hydraulsystem	Hydraulic system	Hydraulisches System	Système hydraulique	Unidad hidráulica	8-11
Elektriskt system	Electrical system	Elektrischer System	Système électrique	Unidad eléctrica	12-13
Kåpor och dekaler	Decals and covers	Abziehbilder und gehäuse	Décalque - coiffe	Etiqueta - caja	14-15
Balkärra	Bale dolly	Sackenkarren	Charette	Carro	16-17
Elschema	Electrical diagram	Elektrisches System	Diagramme électrique	Esquema eléctrico	18
Hydraulikschema	Hydraulic diagram	Hydraulisches Schema	Diagramme hydraulique	Esquema hidráulico	19
Injustering av givare	Adjustment of switches	Schalter	Fin de course	Interruptor	20

3110

VIKTIGT ! NOTE ! WICHTIG ! IMPORTANT ! IMPORTANTE !

- Vid beställning av reservdelar uppge alltid: Produktnummer, serienummer, reservdelsnummer.
- When ordering spare parts state: Product number, serial number, spare part number.
- Wenn Sie Ersatzteile bestellen bitte immer angeben: Produkt nummer, serie nummer, ersatzteil nummer.
- Pour commande des pièces détachées mentionner: Product numero, no de serie, numero de pièces.
- Mencionar lo Siguiete de pedir repuestos: Producto no, no de serie, no de parte.

Product: 4903110-00

	Box 58 576 22 Sävsjö Sweden	
Type *	Date	
Product No * * *	Weight	
Serial No * *		
V ~ Hz		
kW A		
Temperature range of use (standard oil): +5°C to +40°C		
Temperature range of use (special oil): -10°C to +40°C		

- * - XXXX (ex Compactor 3110)
- ** - XXXXX (ex 21001)
- *** - 490XXXX - XX (ex 4903110-00)

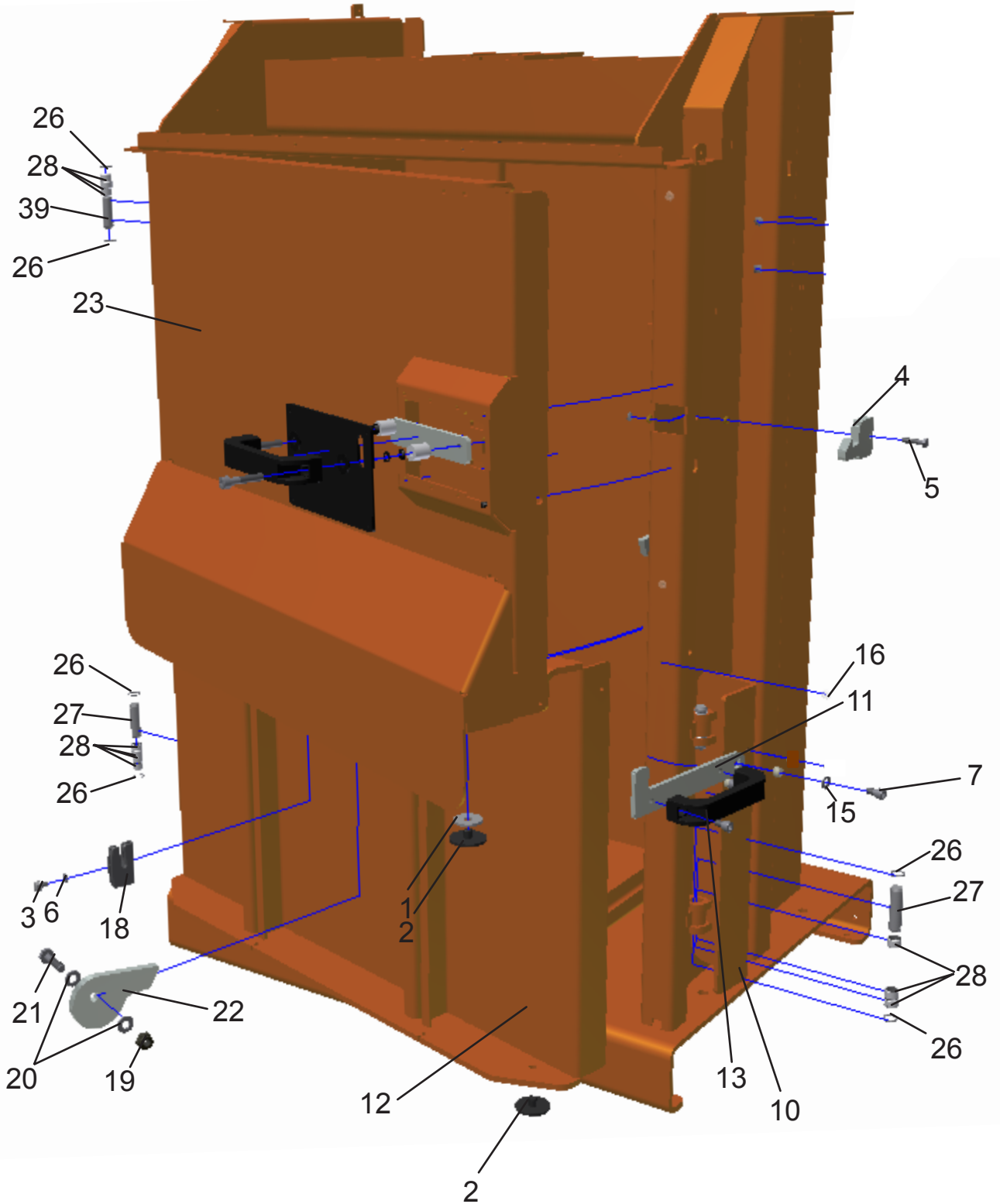
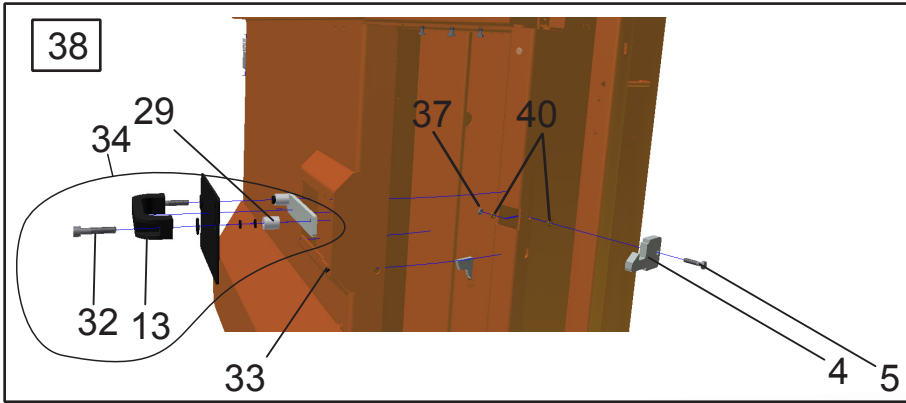

3110

BEHÅLLARE / CHAMBER / BEHÄLTER / CHAMBRE / CÁMARA

Item no.	Part No.	Description Svenska	English	Deutsch	Français	Español	Comments
2	4869535-00	Plastfot	Sliding panel	Gummianslag	Butée en caoutchouc	Tope de goma	
3	4868654-00	Skruv	Screw	Schraube	Vis	Tornillo	MRT-GF M5x10
4	4872294-00	Låshake	Lock hook	Lockhaken	Crochet de verrouillage	Bloqueo de gancho	
5	7252372-51	Skruv	Screw	Schraube	Vis	Tornillo	M6S M6x25 8.8
7	7255448-01	Skruv	Screw	Schraube	Vis	Tornillo	MC6S M8x14
10	4873257-00L	Låsklaff	Door flap	Türkklappe	Battant du porte	Seguro de la puerta	From serial No.117566-
11	4871519-00	Klinka	Shutter latch	Lukenriegel	Verrou de couvercle	Cerrojo de la cubierta	
12	4872842-00L	Nedre dörr	Lower door	Ober tür	Supérieure	Superior	From serial No.117566-Black
13	4864814-00	Handtag	Handle	Griff	Poignée	Mango	BRB 8,4
15	7341164-01	Bricka	Washer	Unterlegsscheibe	Rondelle	Arandela	
16	4869652-00	Glasunderlägg	Plastic pad	Untersatz	Bâti	Base de asiento	
18	4870391-00	Bandkniv	Band knife	Bandmesser	Couteau de lien	Cuchillo para banda	
19	7322120-01	Låsmutter	Lock nut	Gegenmutter	Contre écrou	Contratuercas	M10
20	7341173-01	Bricka	Washer	Unterlegsscheibe	Rondelle	Arandela	BRB 10,5
21	7252499-51	Skruv	Screw	Schraube	Vis	Tornillo	M6S M10x40 8.8
22	4869223-00	Låshake	Latch	Haken	Crochet	Gancho	
23	4872841-00L	Övre dörr/Lucka	Upper door	Obere Tür	Supérieure	Superior	From serial No.117566-
26	7353117-00	Seegersäkring	Clip	Sperring	Circlip	Clip	
27	4866650-00	Gångjärnsaxel	Axle	Achse	Axe	Eje	
28	4871360-00	Glidbussning	Bushing	Buchse	Douille	Buje	
29	4872295-00	Distans	Spacer	Distanz	Entretoise	Espaciador	8,2x18x20
32	7255459-50	Skruv	Screw	Schraube	Vis	Tornillo	MC6S M8x40 12.9
33	7227850-17	Blindnit	Pop rivet	Popniete	Rivet pop	Remache	4,0x16,5
34	4872293-00	Klinka	Latch	Riegel	Pêne de la serrure	Pestillo de la cerradura	
37	7314316-01	Låsmutter	Lock nut	Gegenmutter	Contre écrou	Contratuercas	ML6M M6
38	4880650-00	Handtag, komplett	Handle	Griff	Poignée	Mango	From serial No. 101102
39	4871405-00	Gångjärnsaxel	Axle	Achse	Axe	Eje	
40	4862958-00	Nordlockbricka	Locking washer	Sicherungsscheibe	Rondelle de blockage	Arandela de seguridad	M6

3110
PRESSEHET / POWER UNIT / PRESSEINHEIT /
UNITÉ DE COMPACTAGE / UNIDAD DE COMPACTION

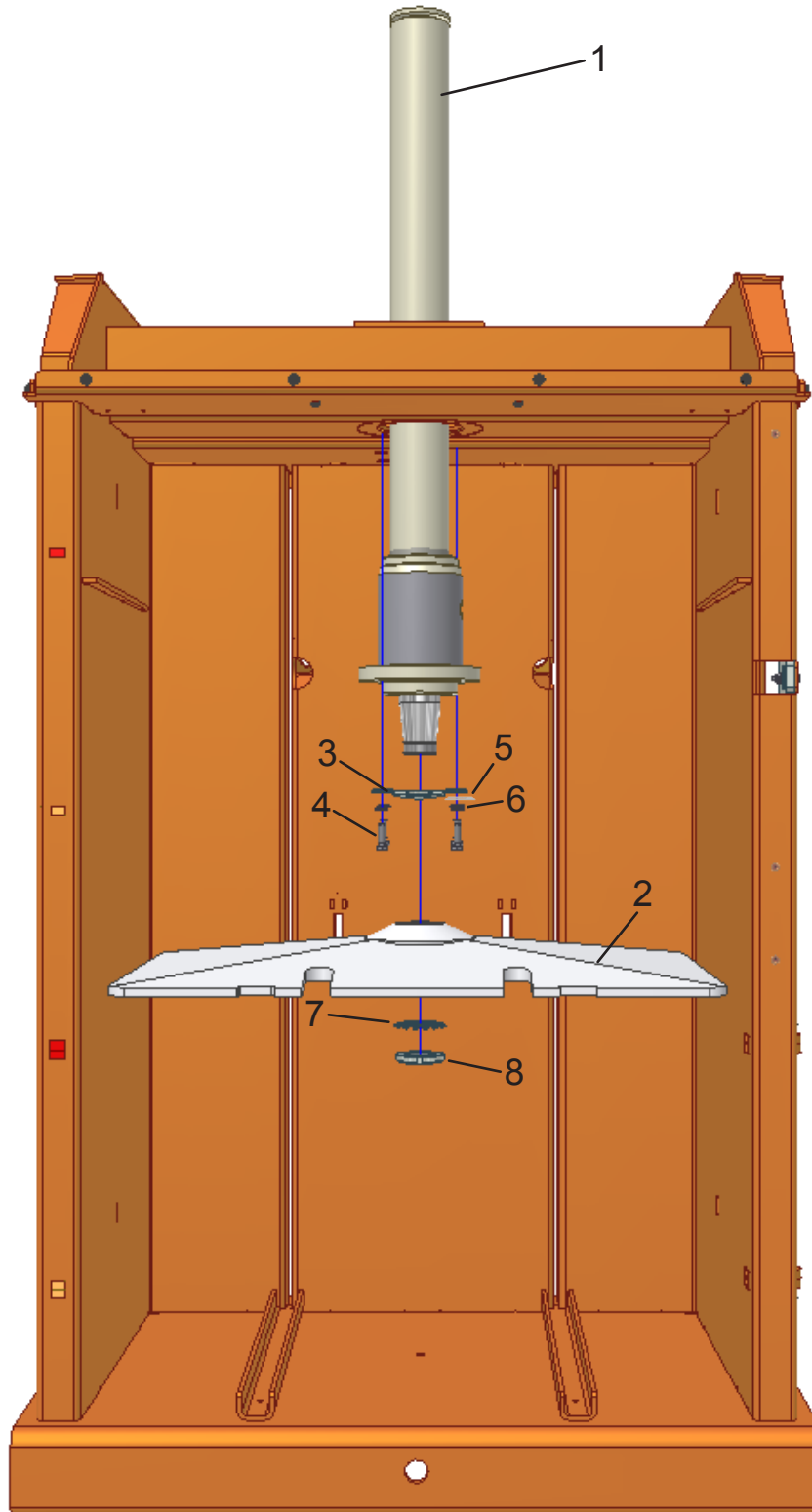

3110
PRESSEHET / POWER UNIT / PRESSEINHEIT /
UNITÉ DE COMPACTAGE / UNIDAD DE COMPACTION

Item no.	Part No.	Description Svenska	English	Deutsch	Français	Español	Comments
1	4870491-01	Presscylinder	Press cylinder	Presszylinder	Verin de compacage	Cilindro de compaction	From serial No. 125635
2	4872493-00	Pressplatta	Press plate	Pressplatte	Plateau de pression	Placa de compactar	
3	4871490-00	Fäste övre gränsläge	Holder, upper limit switch	Halter, grenzschalter	Porteoutil, interrupteur	Soporte, interruptor	
4	7252457-51	Skruv	Screw	Schraube	Vis	Tornillo	M6S M8x35 8.8
5	4871640-00	Shims	Shims	Ausgleichsscheiben	Cales	Cuñas metálicas	
6	7341164-01	Bricka	Washer	Unterlegsscheibe	Rondelle	Arandela	BRB 8,4
7	7322123-90	Skruv	Screw	Schraube	Vis	Tornillo	MB8
8	7325121-30	Mutter	Nut	Mutter	Écrou	Tuerca	KM8

3110
HYDRAULSYSTEM / HYDRAULIC SYSTEM /
HYDRAULISCHES SYSTEM / SYSTEM HYDRAULIQUE /
UNIDAD HIDRÁULICA

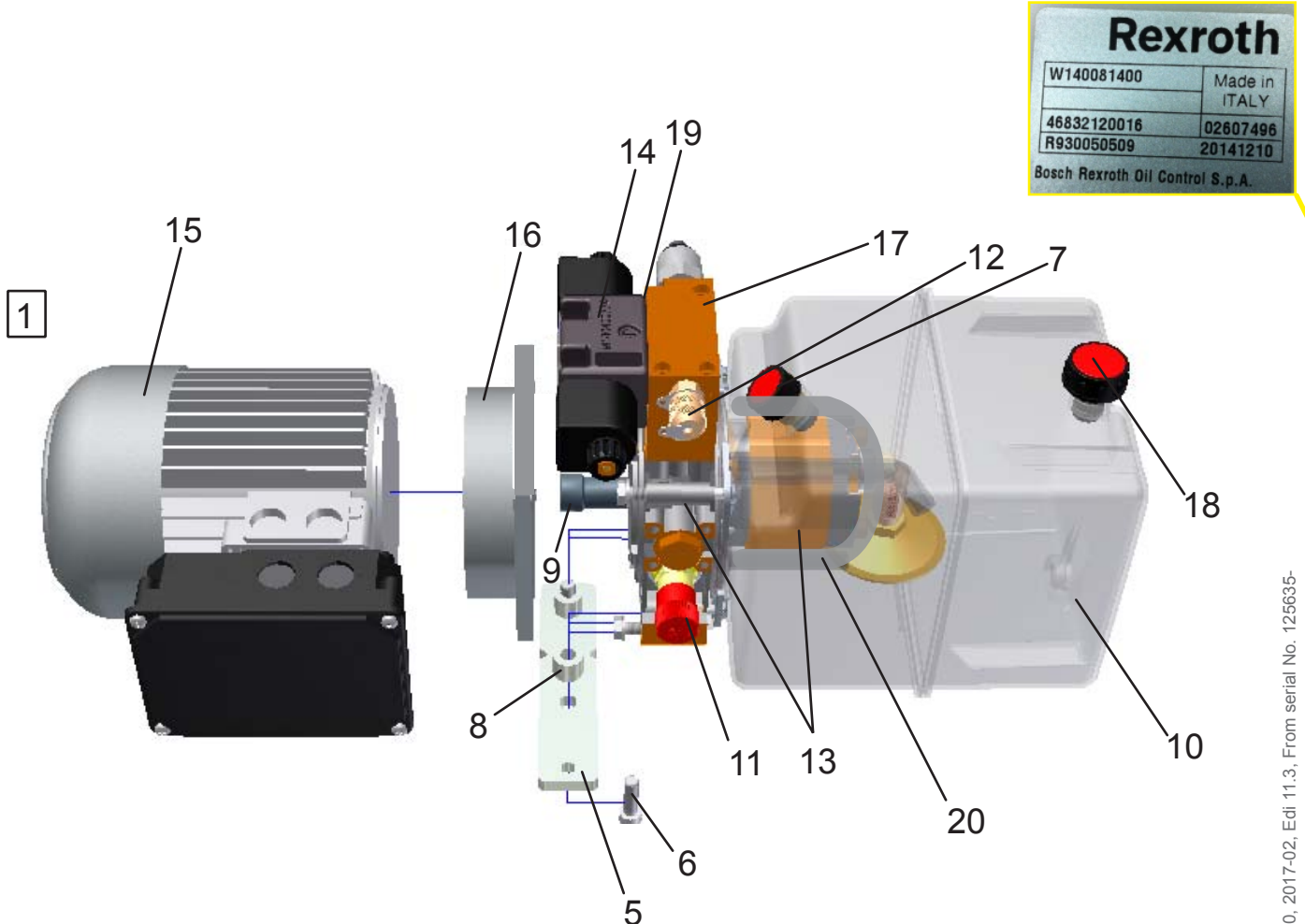
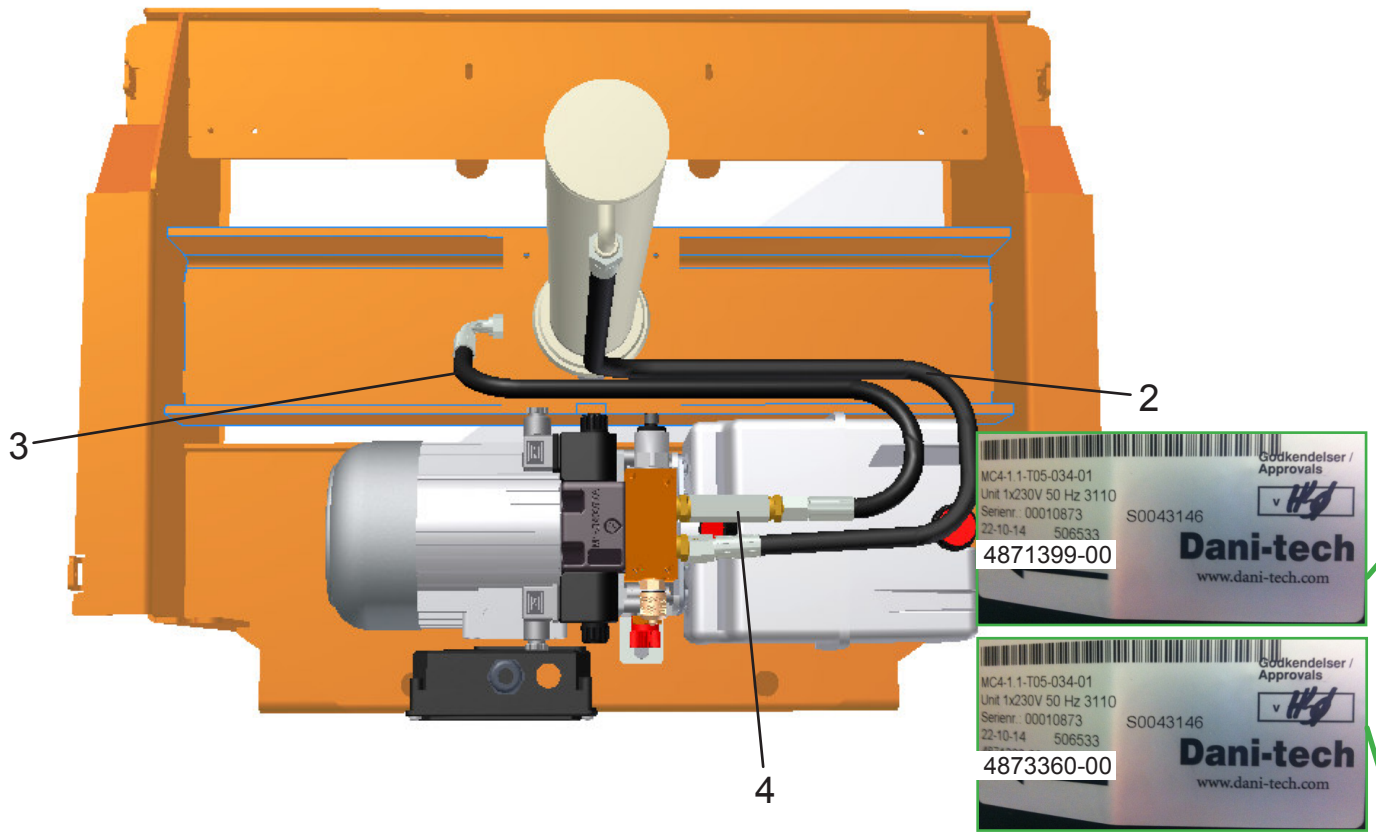

3110
HYDRAULSYSTEM / HYDRAULIC SYSTEM /
HYDRAULISCHES SYSTEM / SYSTEM HYDRAULIQUE /
UNIDAD HIDRÁULICA

NOTE! More hydraulics at next spread!

Item no.	Part No.	Description Svenska	English	Deutsch	Français	Español	Comments
2	4871522-00	Hydraulslang	Hydraulic hose	Hydraulschlauch	Tuyau hydraulique	Manguera hidráulico	From serial no 83510
	4871523-00	Hydraulslang	Hydraulic hose	Hydraulschlauch	Tuyau hydraulique	Manguera hidráulico	To serial no 83510
3	4871523-00	Hydraulslang	Hydraulic hose	Hydraulschlauch	Tuyau hydraulique	Manguera hidráulico	
5	4868392-00	Aggregatplatta	Mounting plate	Befestigungsplatte	Plaque de montage	Placa de montaje	
6	7255504-01	Skruv	Screw	Schraube	Vis	Tornillo	MC6S
8	4871526-00	Distans	Spacer	Distanz	Entretoise	Espaciador	M10x65 8.8
12	4869767-00	Mät nipple	Output pressor gauge	Manometer-anschluss	Un raccard de mesurable	Racor	1/4"
14	4871617-00	Riktningventil	Directional valve	Richtungsventil	Soupape d direction	Valvula d dirección	
18	4869908-00	Andningsfilter	Air filter	Filter	Filtre à air	Taón con filtro	
Dani-tech Note! Program 2.0.3 (Serial no. 117669-117982)							
1	4871399-00	Hydraulaggregat	Hydraulic unit	Hydr. syst.	Syst. hydr.	Unidad hid.	230V, 50 Hz
	4871625-00	Hydraulaggregat utan motor	Hydraulic unit excl. motor	Hydr. syst. ohne Motor	Syst. hydr. sans moteur	Unidad hid. sin motor	
4	4871619-00	Stryp/backventil	Check valve	Rückschlagsventil	Soupape de retenue	Válvula de retención	
7	4871613-00	Plugg	Plug	Pfropf	Bouchon	Tapón	
8	4871526-00	Distans	Spacer	Distanz	Entretoise	Espaciador	
9	4871614-00	Koppling	Coupling	Kupplung	Accouplement	Acaplamiento	(230V, 50Hz)
10	4871623-00	Hydraultank	Oil tank	Öbehälter	Réservoir	Depósito de aceite	
11	4871615-00	Överströmsventil	Overload valve	Ventil	Soupape	Válvula	
13	4871616-00	Mellanstycke med pump	End head with pump	Zwischenstück mit Pump	Adapteur + pompe	Bloque intermed.+ bomba	
15	4871618-00	Elmotor	Electrical motor	Elektrischer Motor	Moteur électrique	Motor eléctrico	230V, 50Hz
	4871629-00	Elmotor	Electrical motor	Elektrischer Motor	Moteur électrique	Motor eléctrico	115V, 60Hz
	4868568-00	Elmotor	Electrical motor	Elektrischer Motor	Moteur électrique	Motor eléctrico	3x200V, 50/60Hz (115V, 60Hz)
16 (9)	4869910-00	Fläns Koppling	Flange Coupling	Gurt Kupplung	Semelle Accouplement	Brida Acaplamiento	(115V, 60Hz)
17	4871624-00	Ventilblock	Adapter	Block	Adaptateur	Bloque	
19	4880008-00	O-ringssats	O-ring kit	Satz dichtungsringe	Joint torique	Junta torica kit	
20	4872725-00	Hydraulrör	Hydraulic pipe	Rohr	Tube	Tubo	
Dani-tech Note! Program 2.1.3 or 2.1.4							
1	4873360-00	Hydraulaggregat	Hydraulic unit	Hydr. syst.	Syst. hydr.	Unidad hid.	230V, 50 Hz
	From serial No. 116985 -117123 and S/N 116787, 116795, 116805, 116816, 116839, 116842, 116843, 116848, 116849, 116853, 116856, 116883. 116915, 116925						
Rexroth Note! Program 2.1.3 (Serial no. 117556-117668 and serial no. 117983-118396)							
1	4873335-00	Hydraulaggregat	Hydraulic unit	Hydr. syst.	Syst. hydr.	Unidad hid.	230V, 50Hz
	4873429-00	Hydraulaggregat	Hydraulic unit	Hydr. syst.	Syst. hydr.	Unidad hid.	115V, 60Hz
	4873435-00	Hydraulaggregat	Hydraulic unit	Hydr. syst.	Syst. hydr.	Unidad hid.	3x200V, 50/60Hz
	4873436-00	Hydraulaggregat	Hydraulic unit	Hydr. syst.	Syst. hydr.	Unidad hid.	3x440/460V, 50/60Hz
	4873483-00	Hydraulaggregat utan motor	Hydraulic unit excl. motor	Hydr. syst. ohne Motor	Syst. hydr. sans moteur	Unidad hid. sin motor	
4	4873472-00	Stryp/backventil	Check valve	Rückschlagsventil	Soupape de retenue	Válvula de retención	
9	4873471-00	Koppling	Coupling	Kupplung	Accouplement	Acaplamiento	
10	4873474-00	Hydraultank	Oil tank	Öbehälter	Réservoir	Depósito de aceite	
11	4873475-00	Överströmsventil	Overload valve	Ventil	Soupape	Válvula	
13	4873465-00	Mellanstycke med pump	End head with pump	Zwischenstück mit Pump	Adapteur + pompe	Bloque intermed.+ bomba	
15	4873470-00	Elmotor	Electrical motor	Elektrischer Motor	Moteur électrique	Motor eléctrico	230V, 50Hz
	4873479-00	Elmotor	Electrical motor	Elektrischer Motor	Moteur électrique	Motor eléctrico	115V, 60Hz
	4873481-00	Elmotor	Electrical motor	Elektrischer Motor	Moteur électrique	Motor eléctrico	3x200V, 50/60Hz
	4873482-00	Elmotor	Electrical motor	Elektrischer Motor	Moteur électrique	Motor eléctrico	3x440/460V, 50/60Hz
17	4873467-00	Ventilblock	Adapter	Block	Adaptateur	Bloque	
19	4873469-00	O-ringssats	O-ring kit	Satz dichtungsringe	Joint torique	Junta torica kit	
20	4872864-00	Hydraulrör	Hydraulic pipe	Rohr	Tube	Tubo	

3110
HYDRAULSYSTEM / HYDRAULIC SYSTEM /
HYDRAULISCHES SYSTEM / SYSTEM HYDRAULIQUE /
UNIDAD HIDRÁULICA

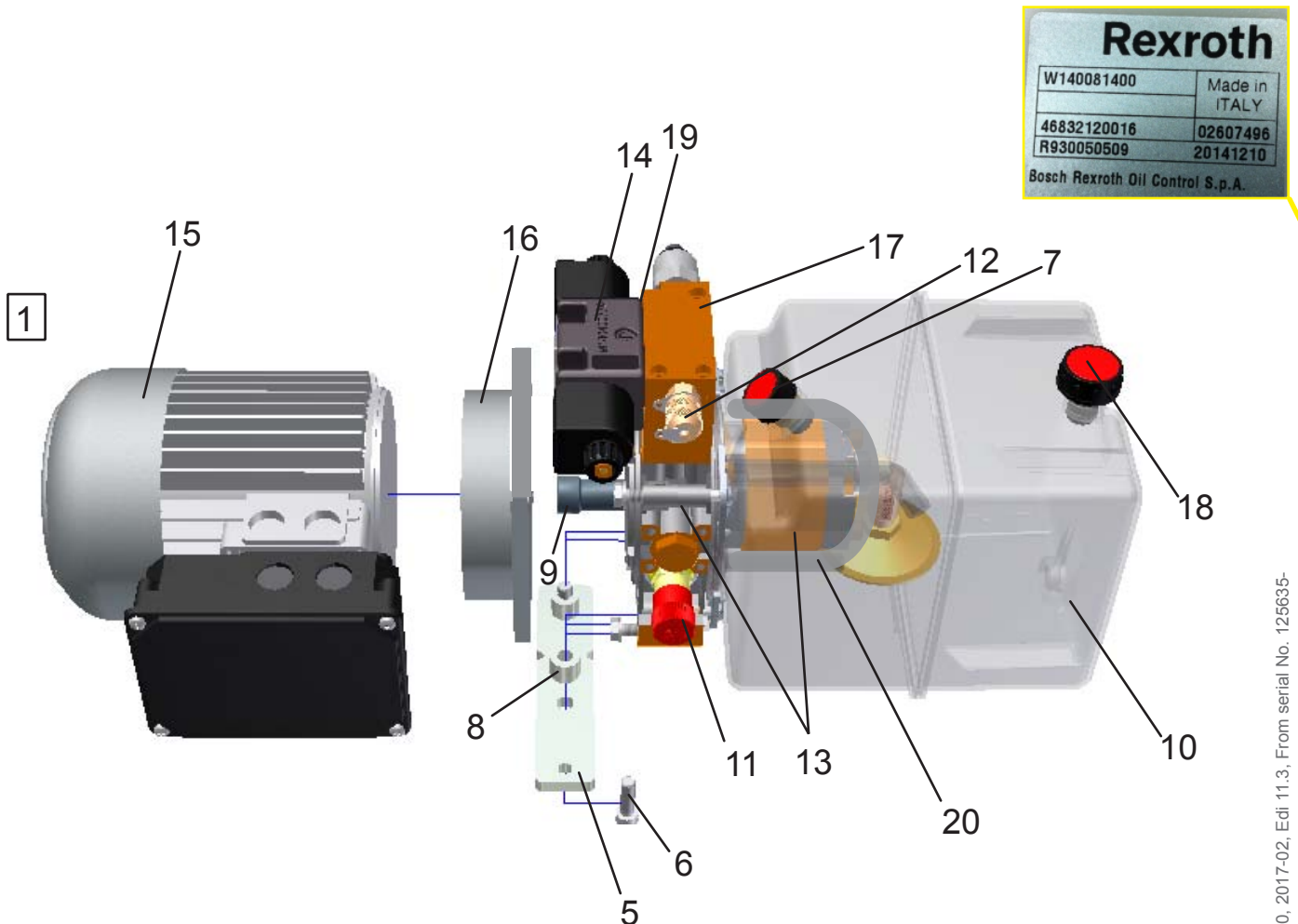
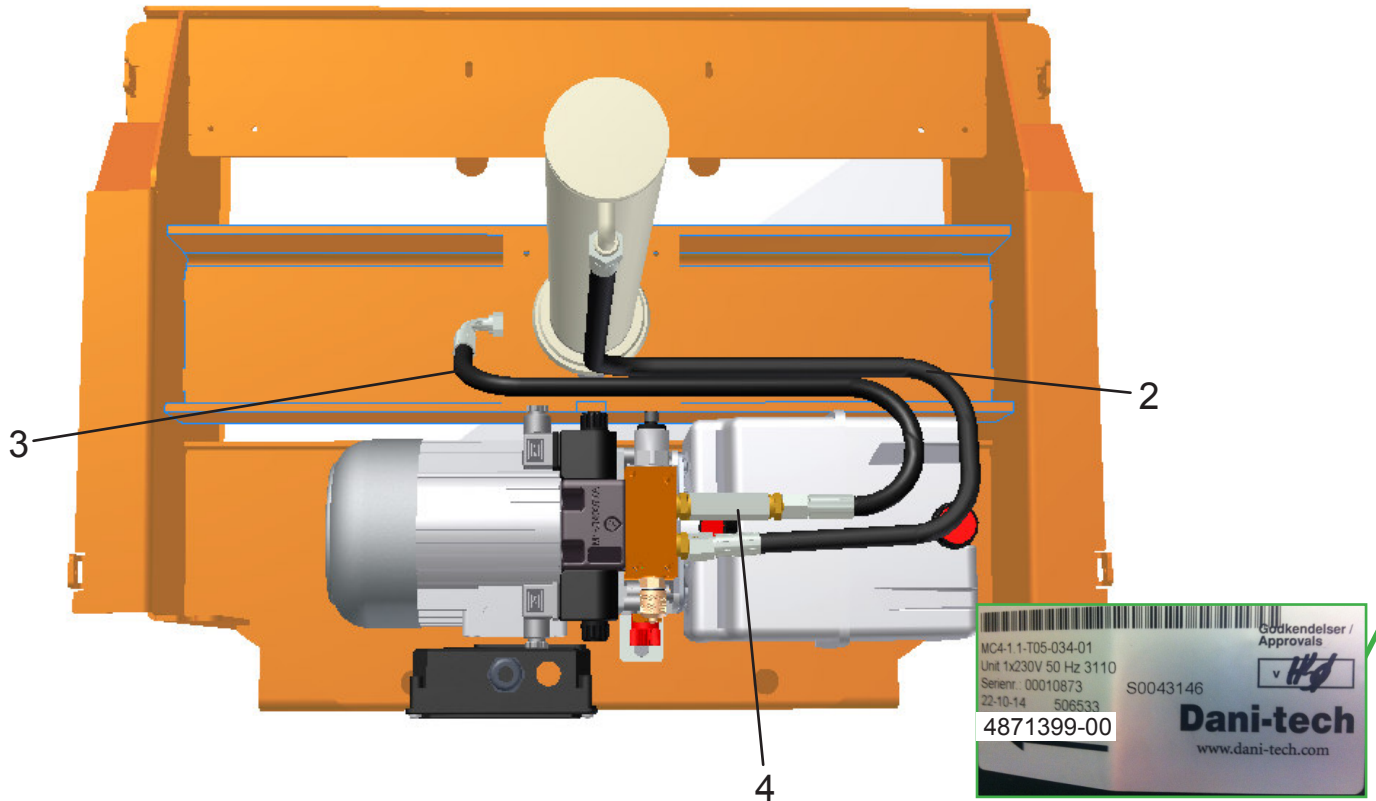

3110
HYDRAULSYSTEM / HYDRAULIC SYSTEM /
HYDRAULISCHES SYSTEM / SYSTEM HYDRAULIQUE /
UNIDAD HIDRÁULICA

Item no.	Part No.	Description Svenska	English	Deutsch	Français	Español	Comments
2	4871522-00	Hydraulslang	Hydraulic hose	Hydraulschlauch	Tuyau hydraulique	Manguera hidráulico	From serial no 83510
	4871523-00	Hydraulslang	Hydraulic hose	Hydraulschlauch	Tuyau hydraulique	Manguera hidráulico	To serial no 83510
3	4871523-00	Hydraulslang	Hydraulic hose	Hydraulschlauch	Tuyau hydraulique	Manguera hidráulico	
5	4868392-00	Aggregatplatta	Mounting plate	Befestigungsplatte	Plaque de montage	Placa de montaje	
6	7255504-01	Skruv	Screw	Schraube	Vis	Tornillo	MC6S M10x65 8.8
8	4871526-00	Distans	Spacer	Distanz	Entretoise	Espaciador	
12	4869767-00	Mät nipple	Output pressor gauge	Manometer-anschluss	Un raccord de mesurable	Racor	1/4"
14	4871617-00	Riktningventil	Directional valve	Richtungsventil	Soupape d direction	Valvula d dirección	
18	4869908-00	Andningsfilter	Air filter	Filter	Filtre à air	Taón con filtro	

Dani-tech		Note! Program 2.0.4 (Serial no. 119911-120371 and 119890-119907)					
1	4871399-00	Hydraulaggregat	Hydraulic unit	Hydr. syst.	Syst. hydr.	Unidad hid.	230V, 50 Hz
	4871625-00	Hydraulaggregat utan motor	Hydraulic unit excl. motor	Hydr. syst. ohne Motor	Syst. hydr. sans moteur	Unidad hid. sin motor	
4	4871619-00	Stryp/backventil	Check valve	Rückschlagsventil	Soupape de retenue	Válvula de retención	
7	4871613-00	Plugg	Plug	Pfropf	Bouchon	Tapón	
8	4871526-00	Distans	Spacer	Distanz	Entretoise	Espaciador	
9	4871614-00	Koppling	Coupling	Kupplung	Accouplement	Acaplamiento	(230V, 50Hz)
10	4871623-00	Hydraultank	Oil tank	Ölbehälter	Réservoir	Depósito de aceite	
11	4871615-00	Överströmsventil	Overload valve	Ventil	Soupape	Válvula	
13	4871616-00	Mellanstycke med pump	End head with pump	Zwischenstück mit Pump	Adapteur + pompe	Bloque intermed.+ bomba	
15	4871618-00	Elmotor	Electrical motor	Elektrischer Motor	Moteur électrique	Motor eléctrico	230V, 50Hz
	4871629-00	Elmotor	Electrical motor	Elektrischer Motor	Moteur électrique	Motor eléctrico	115V, 60Hz
	4868568-00	Elmotor	Electrical motor	Elektrischer Motor	Moteur électrique	Motor eléctrico	3x200V, 50/60Hz (115V, 60Hz)
16	4869910-00	Fläns	Flange	Gurt	Semelle	Brida	
(9)		Koppling	Coupling	Kupplung	Accouplement	Acaplamiento	
17	4871624-00	Ventilblock	Adapter	Block	Adaptateur	Bloque	
19	4880008-00	O-ringssats	O-ring kit	Satz dichtungsringe	Joint torique	Junta torica kit	
20	4872725-00	Hydraulrör	Hydraulic pipe	Rohr	Tube	Tubo	

Rexroth		Note! Program 2.1.4 (Serial no. 118550-119888 and 120372-)					
1	4873335-00	Hydraulaggregat	Hydraulic unit	Hydr. syst.	Syst. hydr.	Unidad hid.	230V, 50Hz
	4873429-00	Hydraulaggregat	Hydraulic unit	Hydr. syst.	Syst. hydr.	Unidad hid.	115V, 60Hz
	4873435-00	Hydraulaggregat	Hydraulic unit	Hydr. syst.	Syst. hydr.	Unidad hid.	3x200V, 50/60Hz
	4873436-00	Hydraulaggregat	Hydraulic unit	Hydr. syst.	Syst. hydr.	Unidad hid.	3x440/460V, 50/60Hz
	4873483-00	Hydraulaggregat utan motor	Hydraulic unit excl. motor	Hydr. syst. ohne Motor	Syst. hydr. sans moteur	Unidad hid. sin motor	
4	4873472-00	Stryp/backventil	Check valve	Rückschlagsventil	Soupape de retenue	Válvula de retención	
9	4873471-00	Koppling	Coupling	Kupplung	Accouplement	Acaplamiento	
10	4873474-00	Hydraultank	Oil tank	Ölbehälter	Réservoir	Depósito de aceite	
11	4873475-00	Överströmsventil	Overload valve	Ventil	Soupape	Válvula	
13	4873465-00	Mellanstycke med pump	End head with pump	Zwischenstück mit Pump	Adapteur + pompe	Bloque intermed.+ bomba	
15	4873470-00	Elmotor	Electrical motor	Elektrischer Motor	Moteur électrique	Motor eléctrico	230V, 50Hz
	4873479-00	Elmotor	Electrical motor	Elektrischer Motor	Moteur électrique	Motor eléctrico	115V, 60Hz
	4873481-00	Elmotor	Electrical motor	Elektrischer Motor	Moteur électrique	Motor eléctrico	3x200V, 50/60Hz
	4873482-00	Elmotor	Electrical motor	Elektrischer Motor	Moteur électrique	Motor eléctrico	3x440/460V, 50/60Hz
17	4873467-00	Ventilblock	Adapter	Block	Adaptateur	Bloque	
19	4873469-00	O-ringssats	O-ring kit	Satz dichtungsringe	Joint torique	Junta torica kit	
20	4872864-00	Hydraulrör	Hydraulic pipe	Rohr	Tube	Tubo	

3110
ELEKTRISKA SYSTEMET / ELECTRICAL SYSTEM /
ELEKTRISCHES SYSTEM / SYSTEM ELECTRIQUE
/ UNIDAD ELÉCTRICA

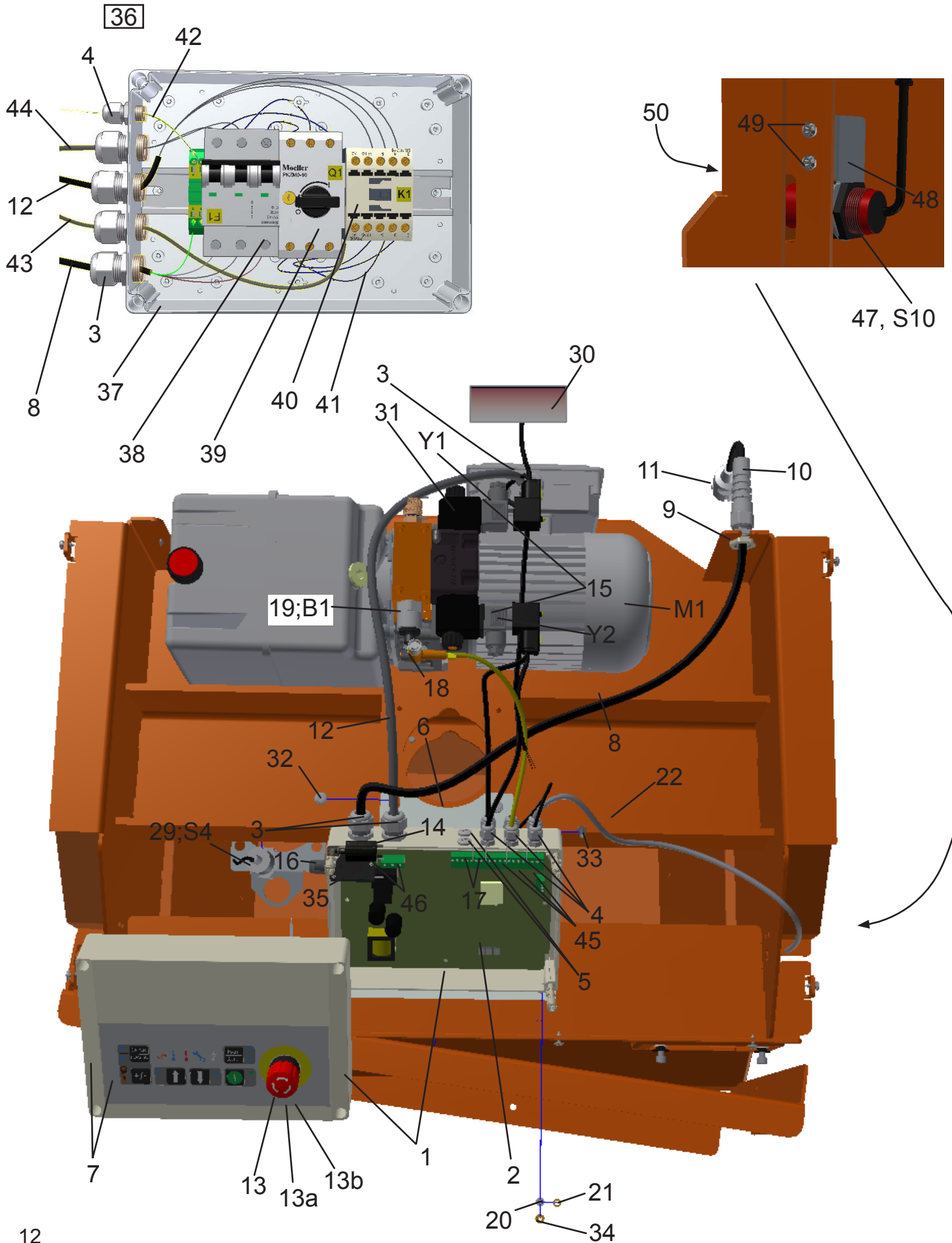

3110
ELEKTRISKA SYSTEMET / ELECTRICAL SYSTEM /
ELEKTRISCHES SYSTEM / SYSTEM ELECTRIQUE
/ UNIDAD ELÉCTRICA

Item No.	Part No.	Description	Svenska	English	Deutch	Francais	Español	Comments
1	4871573-00	Ellåda	Enclosure	Kiste	Boîte	Caja		
2	4870698-00	Styrkort/Kretskort	Printed curcuit board	Elektronikplatte	Plaque d électronique	Place d electrónica	(319-1255D) Needs to be programmed	
2	4870698-01	Styrkort/Kretskort	Printed curcuit board	Elektronikplatte	Plaque d électronique	Place d electrónica	(115V, 60Hz)	
3	4867504-00	Kabelgenomföring	Cable casing	Kabeldurchführung	Gaine	Pasamuros d. cable	M20	
4	4869430-00	Kabelförskrivning	Cable casing	Kabeldurchführung	Gaine	Pasamuros d. cable	M12	
5	4869432-00	Avslutningspropp	Plug	Pfropf	Bouchon	Tapón	M12	
6	4871482-00	Fäste till ellåda	Holder for enclosure	Halter für Kiste	Porteoutil	Soporte		
7	4880652-00	Manöverpanel och lock	Operating panel and cover	Bedinenpult + deckel	Plaque d commande + chape	Placa d manejo + tapa		
8	4861418-01	Kabel	Cable	Kabel	Câble	Cable	(230V, 50Hz)	
	4861984-00	Kabel	Cable	Kabel	Câble	Cable	(115V, 60Hz)	
	4861752-00	Kabel	Cable	Kabel	Câble	Cable	(3x200V, 50/60Hz)	
	4874711-00	Kabel komplett	Cable complete	Kabel komplett	Câble complet	Cable completo	(115V, 60Hz)	
9	4869243-00	Kontramutter	Lock nut	Kontramutter	Écrou de retour	Contra tuerca	M20	
10	4869671-00	Kabelförskrivning	Cable casing	Kabeldurchführung	Gaine	Pasamuros d. cable		
11	4862428-00	Stickpropp	Plug	Stecker	Contact	Enchufe	(230V, 50Hz)	
	4862021-00	Stickpropp	Plug	Stecker	Contact	Enchufe	(115V, 60Hz)	
	4862895-00	Stickpropp	Plug	Stecker	Contact	Enchufe	(3x200V, 50/60Hz)	
12	4861418-01	Kabel	Cable	Kabel	Câble	Cable	(230V, 50Hz)	
	4861984-00	Kabel	Cable	Kabel	Câble	Cable	(115V, 60Hz)	
	4861753-00	Kabel	Cable	Kabel	Câble	Cable	(3x200V, 50/60Hz)	
	4874710-00	Kabel komplett	Cable complete	Kabel komplett	Câble complet	Cable completo	(115V, 60Hz)	
13	4871480-00	Nödstop	Emergency stop	Notausschalter	Bouton arrêt	Boton stop		
13a	4875847-00	Nödstop, låsbar	Emergency stop, lockable	Notausschalter, verschließbar	Bouton arrêt, verrouillable	Boton stop, bloqueable	(US)	
13b	4875847-00	Nyckel	Key	Schlüssel	Clés	llave	(US)	
14	4868991-00	Överströmningsskydd	Overload protection device	Überstromschutz	Dispositif de protecteur contre les surintensités	Interruptor de sobreintensidad	10A	
15	4868063-00	Ventilkontakt	Plug	Stecker	Contact	Enchufe		
16	4868385-00	Membranmutter	Membrane nut	Stecker	Écou	Tuerca		
17	4870382-00	Plint, 3-polig	Block	Klemmenbrett	Block	Bloque	3-pole	
18	4868528-00	Kontakt inkl. kabel	Plug incl. cable	Stecker mit Kabel	Contact + câble	Enchufe + cable		
19	4871620-00	Tryck- och temperaturgivare	Pressure/temperature sensor	Druck- und Temperatursensor	Sonde de pression	Sensor de la presión		
20	7241329-01	Skruv	Screw	Schraube	Vis	Tornillo	MRX M5x16	
21	4861998-00	Låsbricka	Lock washer	Sperrscheibe	Écrou	Tuerca	M5	
22	4867335-00	Kabel	Cable	Kabel	Câble	Cable		
29	4871412-00	Induktiv givare med kabel	Proximity switch with cable	Induktive Näherungsschalter mit Kabel	Proximité arrêter + câble	Proximidad interruptor + cable		
30	4871621-00	Kondensator	Capacitor	Kondensator	Condensateur	Condensador	(230V, 50Hz)	
31	4871626-00	Magnetspole	Coil	Spule	Bobine	Bobina		
32	4861689-00	Skruv	Screw	Schraube	Vis	Tornillo	M6SF-GF, M6x10	
33	7295450-00	Skruv	Screw	Schraube	Vis	Tornillo	RXS B12x19	
34	7331825-51	Blindnitmutter	Rivet nut	Nietmutter	Écrou à rivet	Tuerca de remache	M5x14	
35	4860206-00	Säkring	Fuse	Sicherung	Fusibles	Fusible	T1.6A 250V	
36	4871611-00	Trefaskomplettering	Three phase supplementing	Dreiphasen-Ergänzung	triphase complétant	trifásica completa	3x200V	
37	4871792-00	Ellåda	Enclosure	Kiste	Boîte	Caja	(3x200V)	
38	4869604-00	Dvärgbrytare	Breaker	Shalter	Fin de course	Interruptor		
39	4869439-00	Motorskydds brytare	Motor protection	Motorschutz	Interrupteur	Interruptor	6,3-10	
40	4869441-00	Kontaktor	Relay	Kontaktor	Contacteur	Contactador		
41	4861734-00	Kabel	Cable	Kabel	Câble	Cable		
42	4861737-00	Jordkabel	Ground cable	Kabel erde	Câble	Cable subterráneo		
43	4861738-00	Kabel	Cable	Kabel	Câble	Cable	(Printed circuit card)	
44	4871346-00	Kabel	Cable	Kabel	Câble	Cable		
45	4870384-00	Plint, 4-polig	Block	Klemmenbrett	Block	Bloque	4-pole	
46	4870386-00	Kraftplint, 3-polig	Block	Klemmenbrett	Block	Bloque	3-pole	
	4871400-00	Elstyrning, komplett	Control box, complete	Steuereinheit	Commande	Guía	(230V, 50Hz)	
	4871600-00	Elstyrning, komplett	Control box, complete	Steuereinheit	Commande	Guía	(115V, 60Hz)	
47	4870989-00	Magnetbrytare	Magnetic switch	Magnetschalter	Interrupteur magnétique	Interruptor magnético	From serial no. 113679- (and serial no. 113620) Needs program 2.0.3 or later and PCB card marked 319-1255D or 319-1254D	
48	4872556-00	Fäste	Bracket	Halter	Porte	Soporte		
49	4868654-00	Skruv	Screw	Schraube	Vis	Tornillo	MRT-GF M5x10	
50	7227857-00	Blindnit	Rivet	Niet	Rivet	Remache	4,0x25	

3110
 KÅPOR OCH DEKALER / COVERS AND DECALS / ABZIEHBILDER
 UND GEHÄUSE / DÉCALQUE - COIFFE / ETIQUETA - CAJA

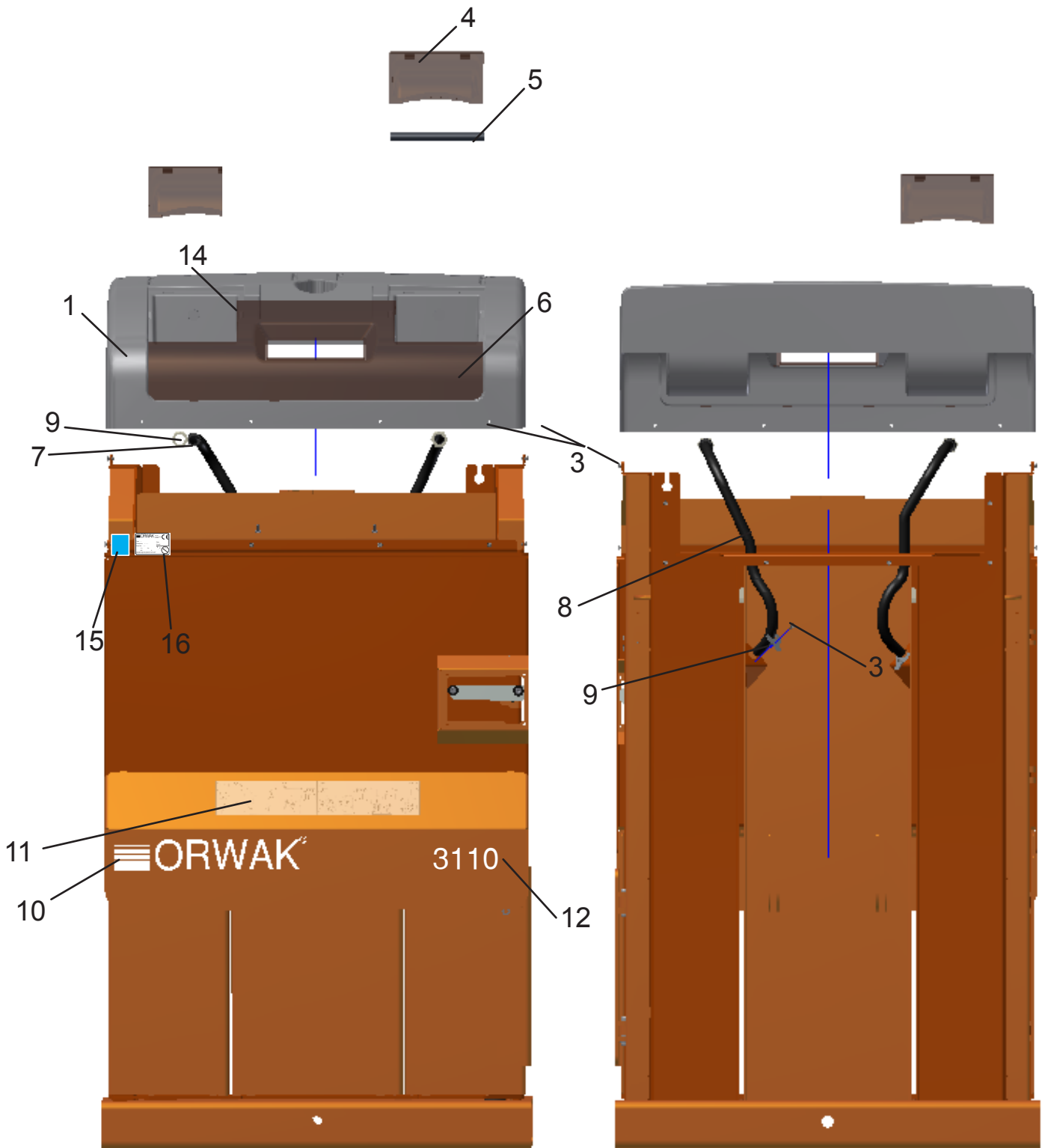

KÅPOR OCH DEKALER / COVERS AND DECALS / ABZIEHBILDER UND GEHÄUSE / DÉCALQUE - COIFFE / ETIQUETA - CAJA

	Part No.	Description Svenska	English	Deutsch	Français	Español	Comments
1	4871330-00	Toppkåpa Changing color from RAL7032 to RAL7037 autumn 2013. RAL7032 are then no longer available.	Top cover	Gehäuse	Coiffe	Caja	Changing color from RAL7032 to RAL7037 autumn 2013.
3	7295446-01	Skruv	Screw	Schraube	Vis	Tornillo	RXS B12x13 To serial no. 111199
	4868654-00	Skruv	Screw	Schraube	Vis	Tornillo	MRT-GF TX M5x10, black From serial no. 111200-
4	4871334-00	Lock	Closing	Deckel	Chape	Tapa	
5	4871417-00	Bandaxel	Band shaft	Achse	Axe	Eje	
6	4871332-00	Frontkåpa	Cover	Gehäuse	Coiffe	Caja	
7	4862830-00	Mutter	Nut	Mutter	Écrou	Tuerca	
8	4867944-00	Skyddslang	Shield hose	Schutzschlauch	Tuyau	Manguera	850 mm
	Note! When ordering 4867944-00; if you order 1 pcs you will receive 1 m.						
9	4870678-00	Bricka	Washer	Unterlegsscheibe	Rondelle	Arandela	
10	4871496-00	Dekal "ORWAK"	Decal "ORWAK"	Abziehbild "ORWAK"	Décalque "ORWAK"	Etiqueta "ORWAK"	
11	4871528-00	Instruktionsdekal	Instruction plate	Anleitungsschild	Plaquette de instruction	Letrero de instrucción	
12	4871495-00	Modelldekal	Decal	Abziehbild	Décalque	Etiqueta	
14	4870003-00	Dekal	Decal	Abziehbild	Décalque	Etiqueta	"Overload protection device"
15	4870193-00	Dekal Find the operating manual at " www.tomracompaction.com "	Decal	Abziehbild	Décalque	Etiqueta	
16		Dataskylt	Data plate	Datenschild	Placa de dato	Plaque de données	
	4870489-00	Bandletare	Strap guide	Gurtführung	Guide de sangle	Correa guía	

3110
BALKÄRRA / BALE TROLLEY / SACKENKARREN /
CHARRETTE / CARRO

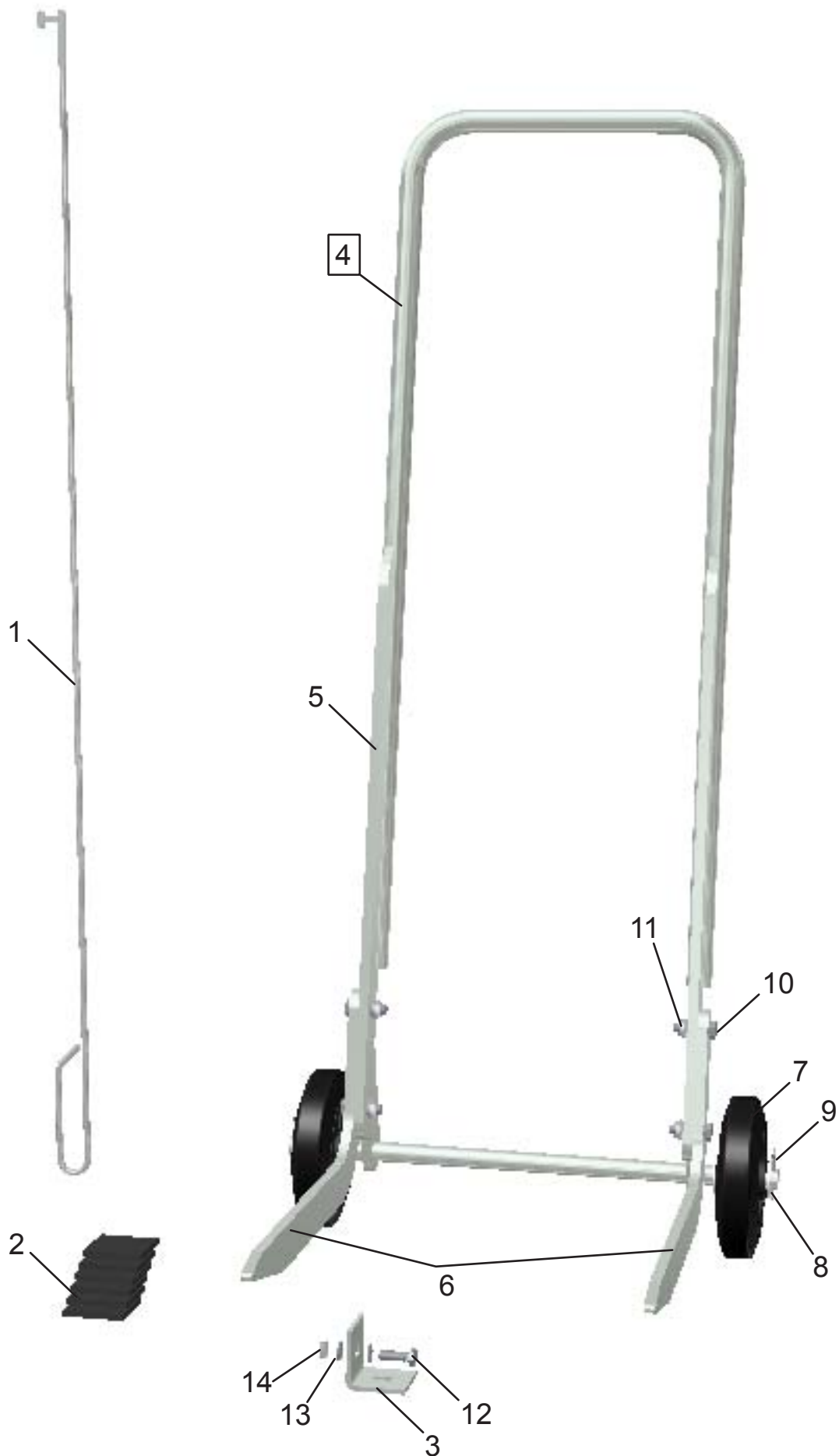

3110

BALKÄRRA / BALE TROLLEY / SACKENKARREN / CHARRETTE / CARRO

	Part No.	Description	English	Deutsch	Français	Español	Comments
1	4871525-00	Bandkrok	String hook	Schnurhaken	Crochet de lien	Gancho de banda	
2	4865407-00	Gummiplatta	Rubber plate	Gummiplatte	Plaque de caoutchouc	Placa de caucho	
3	4865321-00	Golväste	Floor bracket	Halter	Porteoutil	Soporte	
4	4871540-00	Balkärra	Bale trolley	Sackekarren	Charrette	Carro	
5	4871539-00	Bygel					
6	4871538-00	Gafflar	Fork	Gabel	Fourchette	Horquilla	
7	4862953-00	Hjul	Wheel	Rad	Roulette	Rueda	
8	7341191-21	Bricka	Washer	Unterlegsscheibe	Rondelle	Arandela	SRB 21x36x3
9	7216187-00	Saxpinne	Split pin	Splint	Goupille fendue	Pasador elástico	SP 3,2x40
10	7252497-51	Skruv	Screw	Schraube	Vis	Tornillo	M6S, M10x35
11	7322120-01	Låsmutter	Lock nut	Gegenmutter	Contre écrou	Contratuercas	M10
12	7252453-51	Skruv	Screw	Schraube	Vis	Tornillo	M8x25
13	7341164-01	Bricka	Washer	Unterlegsscheibe	Rondelle	Arandela	BRB 8,4
14	7314318-01	Mutter	Nut	Mutter	Écrou	Tuerca	M8

ELKRETSSCHEMA / ELECTRICAL DIAGRAM / ELEKTRISCHES SYSTEM / DIAGRAMME ÉLECTRIQUE / ESQUEMA ELÉCTRICO

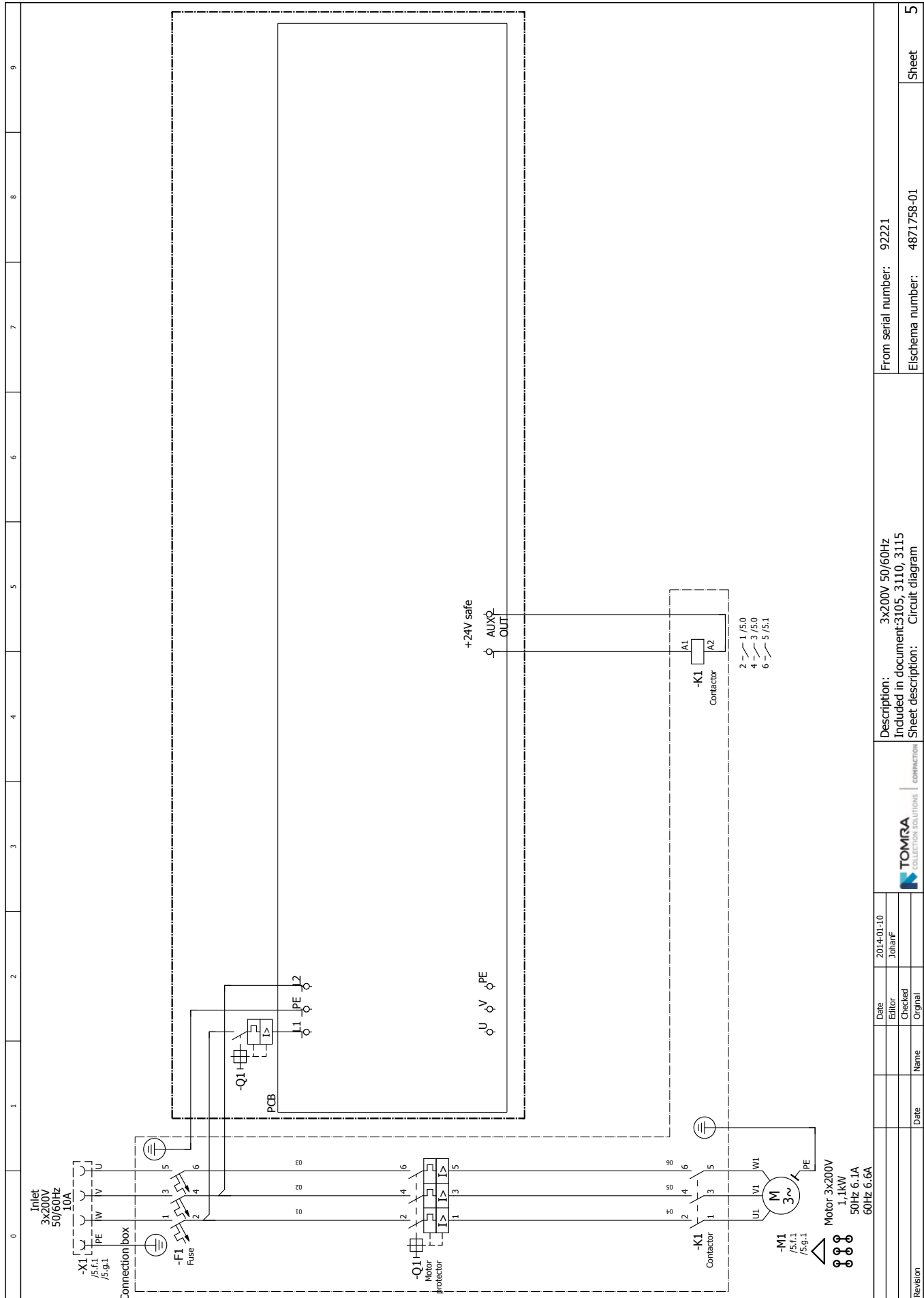

Revision		Date	Name	Checked	Date	Description: 3x200V 50/60Hz Included in document: 3105, 3110, 3115 Sheet description: Circuit diagram		From serial number: 92221	Sheet
		2014-01-10	JohanF					4871758-01	5
				Original					

HYDRAULIKSCHEMA / HYDRAULIC DIAGRAM / HYDRAULISCHES SYSTEM / DIAGRAMME HYDRAULIQUE / ESQUEMA HIDRÁULICO

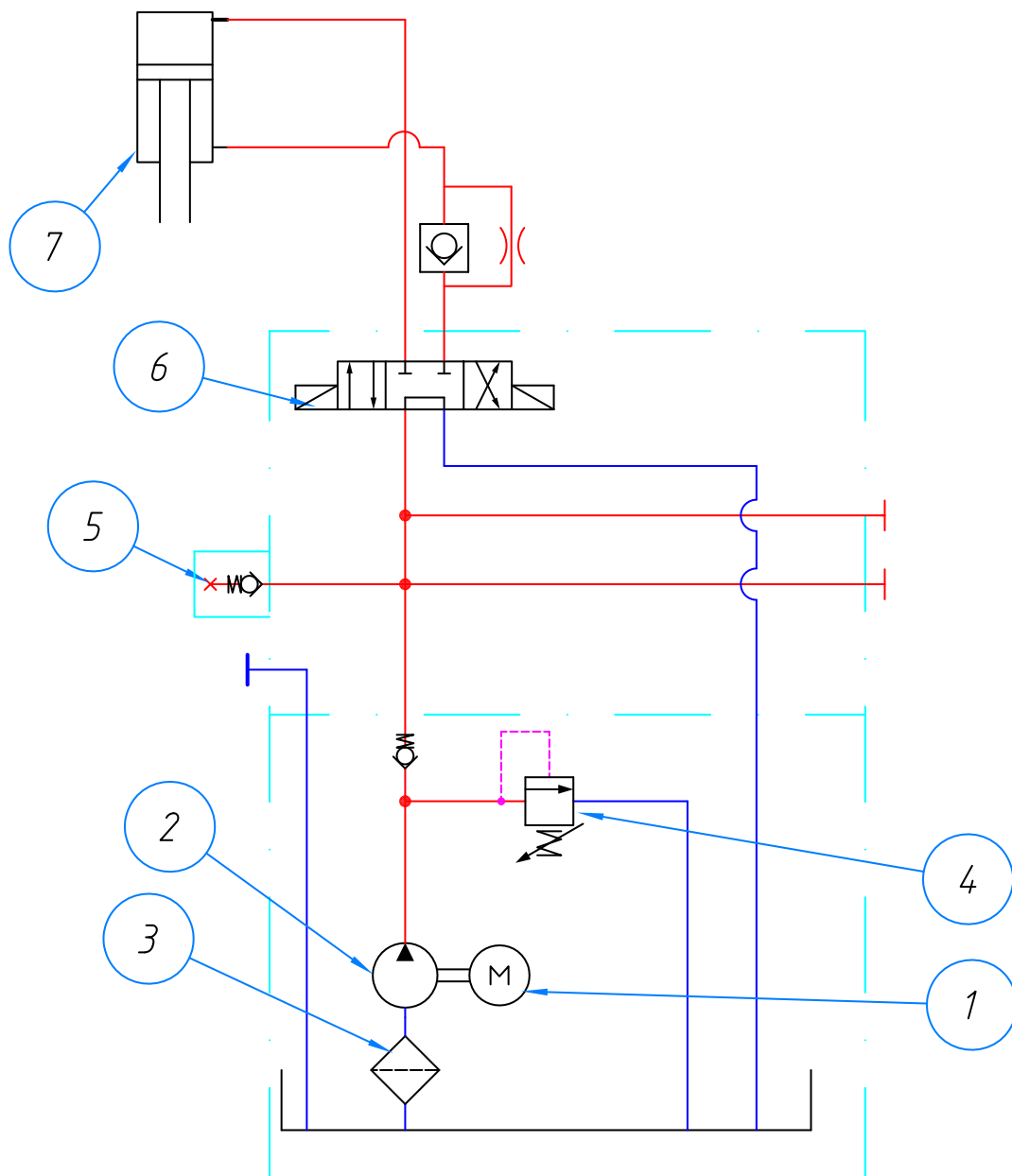

Item Description

no. Svenska

- 1 Elmotor
- 2 Pump
- 3 Sugfilter
- 4 Överströmsventil
- 5 Mät nipple

- 6 Riktningventil
- 7 Presscylinder

English

- Electrical motor
- Pump
- Suction filter
- Overload valve
- Output pressure gauge
- Directional valve
- Press cylinder

Deutsch

- Elektrischer Motor
- Pumpe
- Saugsieb
- Ventil
- Manometeranschluss
- Richtungsventil
- Presszylinder

Français

- Moteur électrique
- Pompe
- Filtre
- Soupape
- Un raccord de mesurable
- Soupape de direction
- Verin de compactage

Español

- Motor eléctrico
- Bomba
- Filtro
- Válvula
- Racor
- Válvula de dirección
- Cilindro de compactacion

INJUSTERING AV BRYTARE / ADJUSTMENT OF SWITCHES / SCHALTER / FIN DE COURSE / INTERRUPTOR

S4 - upper limit switch

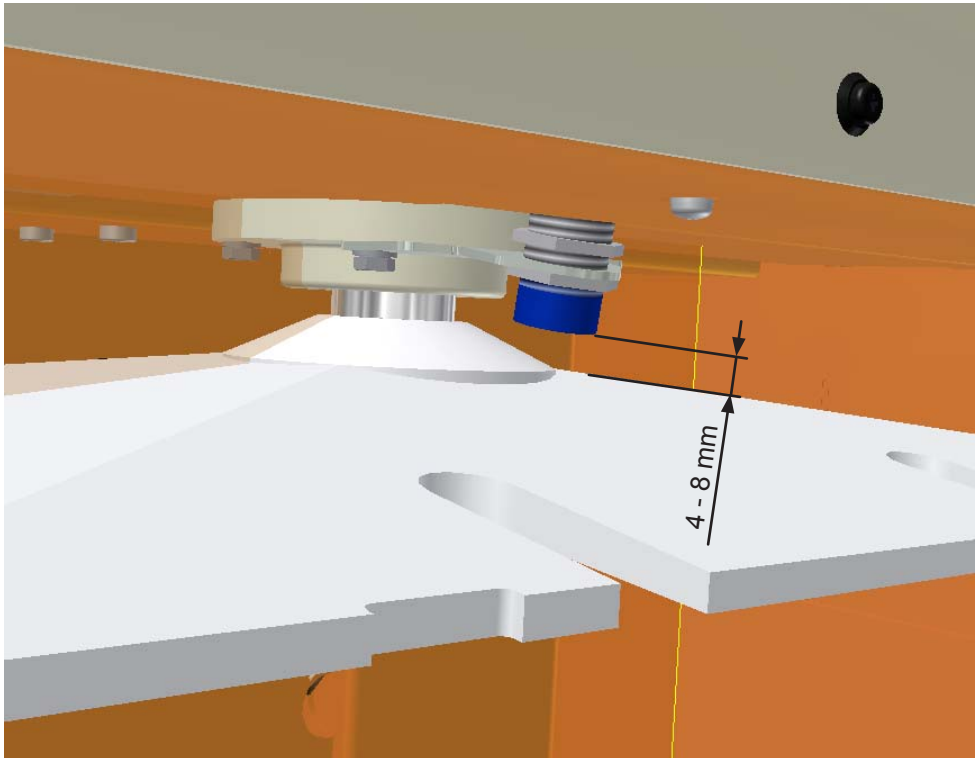

S10 - door magnet switch

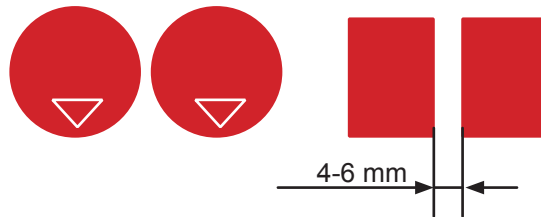

COMPACTION SOLUTIONS FOR MOST TYPES OF WASTE

ORWAK develops solutions for sorting and recycling waste materials that improve business efficiency, contribute to a cleaner working and natural environment to provide the best total waste handling economy.

We offer an innovative range of products that promotes sorting at source and make waste management more profitable.

ORWAK AB
Box 58
S-57622 Sävsjö
SWEDEN
Tel: +46-(0)382-15700
info@orwak.com

www.orwak.com

