

INSTRUCTION MANUAL

Installation | Maintenance | Use | Safety

MEAT MINCER



Models

PCI.10

PCL.10

PCI.22

PCL.22

PCL.98



Image merely illustrative.
Appearance of the equipment
varies by model.



IMG BRASIL - Gastronomy Machinery Industry Ltda.

TABLE OF CONTENTS

1.	Safety Information.....	3
1.1	General Warnings.....	3
2.	Technical Characteristics.....	4
2.1	Main Components.....	4
2.2	Technical Data.....	5
3.	Installation.....	6
3.1	Equipment Layout	6
3.2	Electrical Connection.....	7
3.3	Safety Measures and User Instruction	10
4.	Use of equipment	11
4.1	Utility.....	11
4.2	Commands	11
4.3	Operating Procedures	12
5.	Cleaning and Maintenance.....	15
5.1	Cleaning Procedures and Products Used	15
5.2	Maintenance and Procedures in Case of Breakdowns	16
6.	Annexes.....	19
	Electrical Schematic PCI / L.10 / 22 - Voltage 110 or 220 V 60 Hz MF	19
	Electrical Schematic PCI / L.10 / 22 - Voltage 220 V 50 Hz MF	20
	Electrical Schematic PCL.98 - Voltage 110 V 60 Hz MF	21
	Electrical Schematic PCL.98 - Voltage 220 V 60 Hz MF	22
	Electrical Schematic PCL.98 - Voltage 220 V 50 Hz MF	23
	Electrical Schematic PCL.98 - Voltage 220 V 50 Hz or 60 Hz TF	24
	Electrical Schematic PCL.98 - Voltage 380 V 50 Hz or 60 Hz TF	25
	Blown up Design	26
	List of Replacement Parts.....	28



ATTENTION!

The characteristics, pictures and figures presented in this manual should be considered for information. IMG BRASIL reserves the right to make such modifications as may be deemed necessary without prior notice.

1. Safety Information

1.1 General Warnings

- Cautions / precautions must be observed when installing, using, maintaining and discontinuing use of this equipment;
- Before carrying out any operation (assembly, utilization (use), maintenance and reuse after prolonged use of the equipment), read the manual carefully;
- The equipment must be used by trained personnel familiar with the use and safety standards described in this manual;

This equipment is not intended for use by persons (including children) with reduced physical, sensory or mental capacities, or people with lack of experience and knowledge, unless they have received instructions regarding the use of the equipment or are under the supervision of a person responsible for their safety;

- It is recommended that children be supervised to ensure that they are not playing with the equipment;
- In case of change of the personnel that will work with the equipment, the new operator must be educated about the standards and the operation of the same one;
- The operator must use the **Adequate PPE's** (equipment for individual safety). As for example: use touches the hair avoiding that they lock in the moving parts of the machine;
- The operator must always be aware of situations that can cause a risk of accidents and avoid them.
- For example: avoid working with loose uniform sleeves, where they can lock in moving parts, causing accidents;
- After being held to read and answered all the questions, this manual must be stored carefully in place of easy access, known by all the people who will operate the equipment and made available for the people who carry out maintenance, to any queries. Whenever any questions arise, be sure to check the manual. Do not operate the equipment in any way with doubts;
- In the installation, it is essential to make this manual available to the professionals who will do the same;
- Never place your hands, fingers or objects into the power socket when the unit is turned on as this may cause an accident;
- Use only the socket to push the meat through the grinderr's mouthpiece, as it was designed for this function;
- Before starting cleaning and any maintenance, it is essential to disconnect the equipment from the mains;
- Periodically check the condition of the cables and electrical parts;
- Do not leave the equipment switched on unattended.



ATTENTION!

Do not perform repairs on your own. Refer servicing to qualified service personnel. Use only original parts in your equipment.

2. Technical Features

2.1 Main Components

For the equipment described in this manual, safety in use, cleaning, maintenance and maximum cleaning are guaranteed by the design and special design of all parts and also by using stainless steel and other materials suitable for contact with the food.

The equipment was built with the following features:

- case and tray made of stainless steel, which has higher corrosion resistance than other steels. It is a material resistant to the attack of several corrosive agents;
- Body of nozzle and endless spool on PCL equipment models PCL.10, PCL.22 and PCL.98 are made of tin coated carbon steel, protecting the steel surface from corrosion. For the PCI model PCI.10 and PCI.22 are stainless steel. Both materials are non-toxic and ideal for contact with food.
- Discs and cross blades made from tempered carbon steel, avoiding oxidation and increasing the life of the parts.

The following are the main components of the equipment:

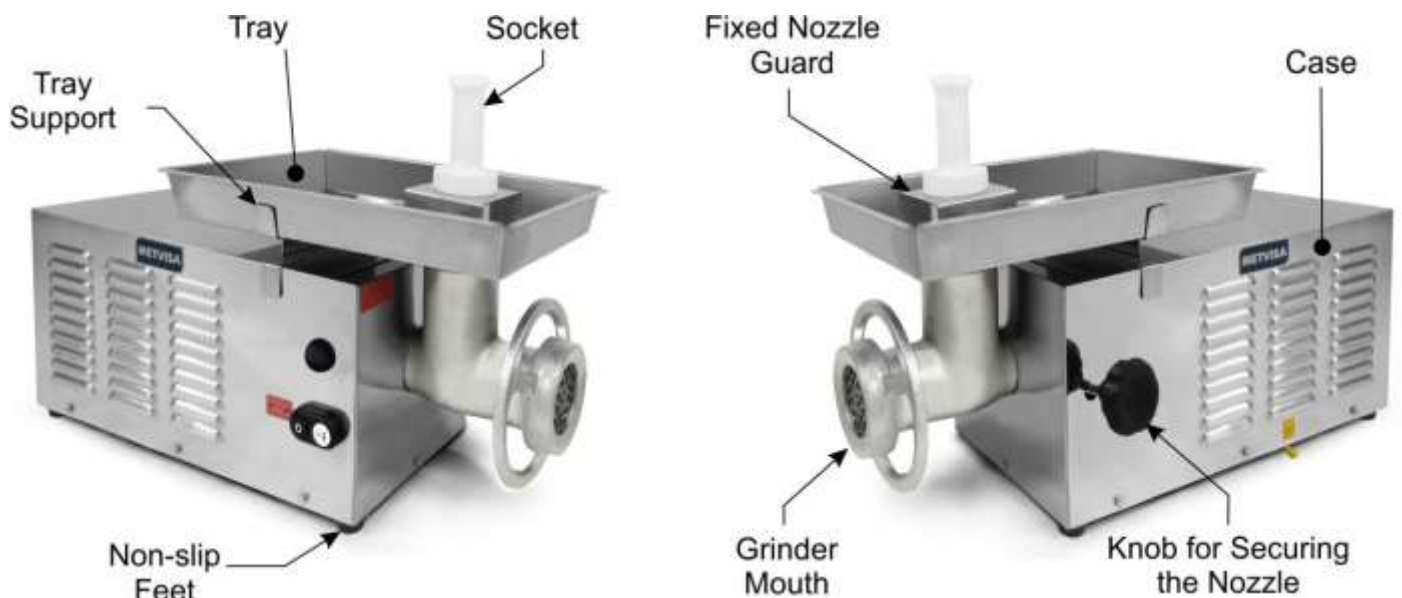

Note: For exploded design with spare parts list, see the attachments.

2.2 Technical Data

Model	Nominal Use Measures LengthxHt.xDepth (mm) *	Net Weight (kg)	Voltage (V)	Rated Current (A)	Discs (Ø mm hole)	Capacity (kg/h) **	Lubricant SAE140 (ml)
PCI10110M604	280x450x790	30.5	110	16.4	5 or 8	150	200
PCI10220M501	280x450x790	30.5	220	6.5	5 or 8	150	200
PCI10220M502	280x450x790	30.5	220	6.5	5 or 8	150	200
PCI10220M504	280x450x790	30.5	220	6.5	5 or 8	150	200
PCI10220M604	280x450x790	30.5	220	6.9	5 or 8	150	200
PCI22110M604	280x450x830	32.2	110	19.7	5 or 8	200	200
PCI22220M501	280x450x830	32.2	220	8.4	5 or 8	200	200
PCI22220M502	280x450x830	32.2	220	8.4	5 or 8	200	200
PCI22220M504	280x450x830	32.2	220	8.4	5 or 8	200	200
PCI22220M604	280x450x830	32.2	220	11.8	5 or 8	200	200
PCL10110M604	280x450x635	32.0	110	16.4	5 or 8	150	200
PCL10220M501	280x450x635	32.0	220	6.5	5 or 8	150	200
PCL10220M502	280x450x635	32.0	220	6.5	5 or 8	150	200
PCL10220M504	280x450x635	32.0	220	6.5	5 or 8	150	200
PCL10220M604	280x450x635	32.0	220	6.9	5 or 8	150	200
PCL22110M604	280x450x690	37.0	110	19.7	5 or 8	200	200
PCL22220M501	280x450x690	37.0	220	8.4	5 or 8	200	200
PCL22220M502	280x450x690	37.0	220	8.4	5 or 8	200	200
PCL22220M504	280x450x690	37.0	220	8.4	5 or 8	200	200
PCL22220M604	280x450x690	37.0	220	11.8	5 or 8	200	200
PCL98110M605	390x620x830	61.5	110	26	5 or 8	400	400
PCL98220M505	390x620x830	61.5	220	11.4	5 or 8	400	400
PCL98220M605	390x620x830	61.5	220	12.6	5 or 8	400	400
PCL98220T605	390x620x830	62.5	220	6.4	5 or 8	400	400
PCL98380T505	390x620x830	62.5	220	3.7	5 or 8	400	400

* For all grinder models the height measurement was considered with the socket embedded in the tray. On PCI models.10 and PCI.22 the bottom measurement was considered with the funnel mounted on the nozzle of the grinder.

** May vary due to user's working speed and according to the disc used and processed product.

Noise level: 70 db.



ATTENTION!

Features like: model, serial number and voltage of the equipment are provided on the label (figure below). Before installation, check that the power supply voltage of the equipment corresponds to that of the mains.

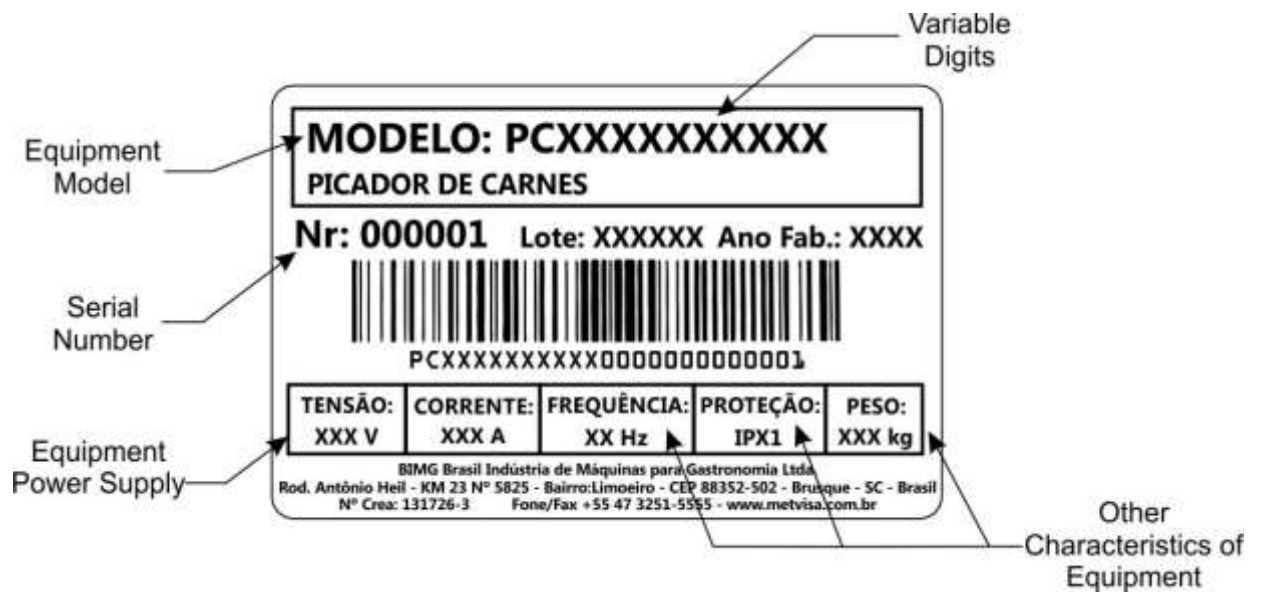

3. Installation

3.1 Equipment Layout

The connection to the mains and the arrangement for operation must be carried out by a qualified professional. Check that the voltage of the equipment matches the mains voltage.

- In the installation, it is essential to make this manual available to the professionals who will do the same.

To ensure correct operation and safety, the machine must be positioned in an airy environment and on a sufficiently wide, level, dry and stable support surface, away from heat sources and water taps, and at a medium height of 80 cm. Install your equipment by leaving a free area on the front, a distance of at least 60 cm above the equipment and a distance of at least 30 cm around it, so that it has enough space for inspection, maintenance, cleaning and use.

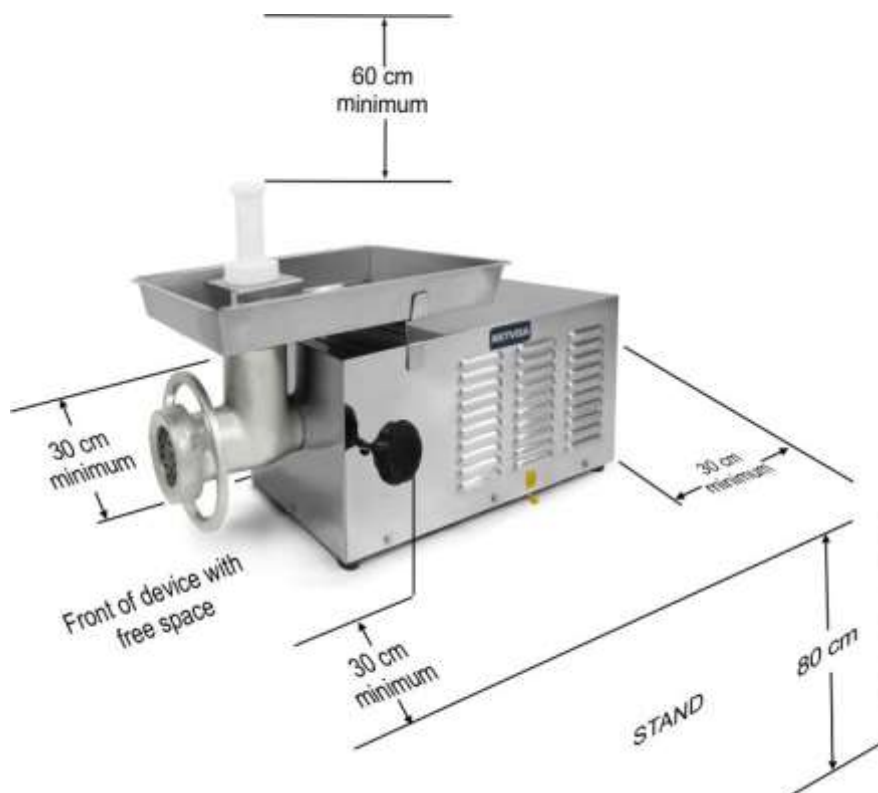



ATTENTION!

The installation and the place where the equipment is to be disposed of must comply with the rules of risk prevention and safety at work (Regulatory standard NR-12 for Brazil or according to the regulation in force in your country).

The manufacturer shall not be liable for any direct or indirect damages caused by non-compliance with these standards and other instructions presented in this manual.

3.2. Electrical connection

The equipments are supplied with a power cord to be connected to an electrical outlet.

For Single Phase (MF) PCL grinder models.10 / PCL.22 / PCI.10 / PCI.22, power cords are supplied with stamped plugs, where the type of plug varies by country. The installation of the equipment must be done by a qualified technician for this function and observing the current regulations of the country, especially with regard to the ground connection (if applicable).

For Single Phase (MF) PCL.98 grinder models, are supplied with power cables with industrial type **2P + T** plugs (2 poles + ground), following a regulation in force in Brazil. The 110 V grinders 98 (MF) are supplied with an industrial plug that supports up to 32 A, while the 98 (MF) 220 V grinders have an industrial plug that supports up to 16 A.

In this type of connection, the plug has 3 round pins, the larger diameter of the grounding pin (ground pin). It is mandatory to connect all the connection poles before connecting the equipment, as well as a good ground connection, according to the current regulations.

Detail of industrial type 2P + T plugs (2 Poles + Ground):

- Yellow plug for 110 V voltage, current up to 32 A.

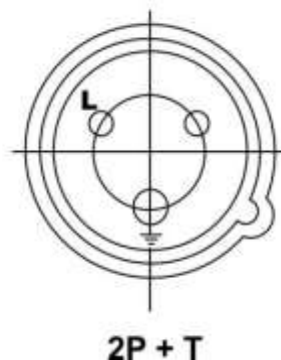

- Blue plug for 220 V voltage, current up to 16 A.

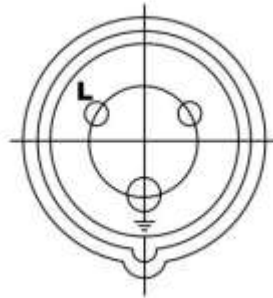

2P + T

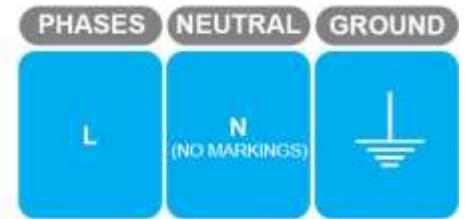

Note: The PCL grinder power supply.98 (MF) 110 V, require a 25 A circuit breaker; PCL.98 grinders (MF) 220 V, require a 16 amp circuit breaker.

Already the three-phase grinder (TF) PCL.98 models, are supplied with power cables with industrial type **3P + N + T plugs (3-pole + neutral + ground)** for 220 V or 380 V voltages. Both can support up to 16 A, following current regulations.

In this type of connection, the plug has 3 round pins, the larger diameter of the grounding pin (ground pin). It is mandatory to connect all the connection poles before connecting the equipment, as well as a good ground connection, according to the current regulations.

Detail of industrial type 3P + N + T plugs (3-pole + neutral + earth):

- Blue plug for 220 V voltage, current up to 16 A.

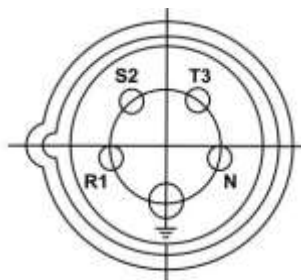

3P + N + T

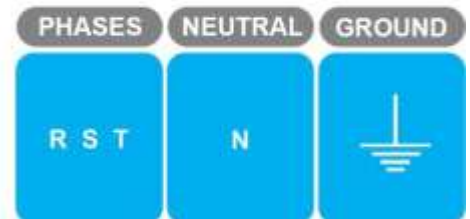

- Red plug for voltage 380 V, current up to 16 A.

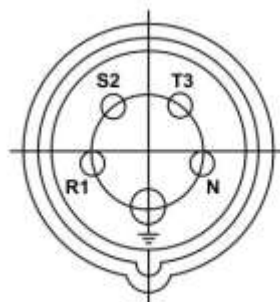

3P + N + T

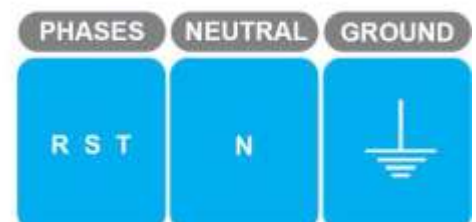

The maintenance procedure on the power cable and / or the power plug of the equipment must be carried out by an authorized agent or qualified person. When reassembling these components and making the points connections, you can also use the markings on the inside of the plug in your plastic region as a reference.

In these markings, the grounding pin (ground pin) is indicated with the grounding symbol, the pin of the neutral conductor is indicated with the letter "N" and the phase pins. The symbols vary according to the model of the plug (previous pictures). Check the following figure:

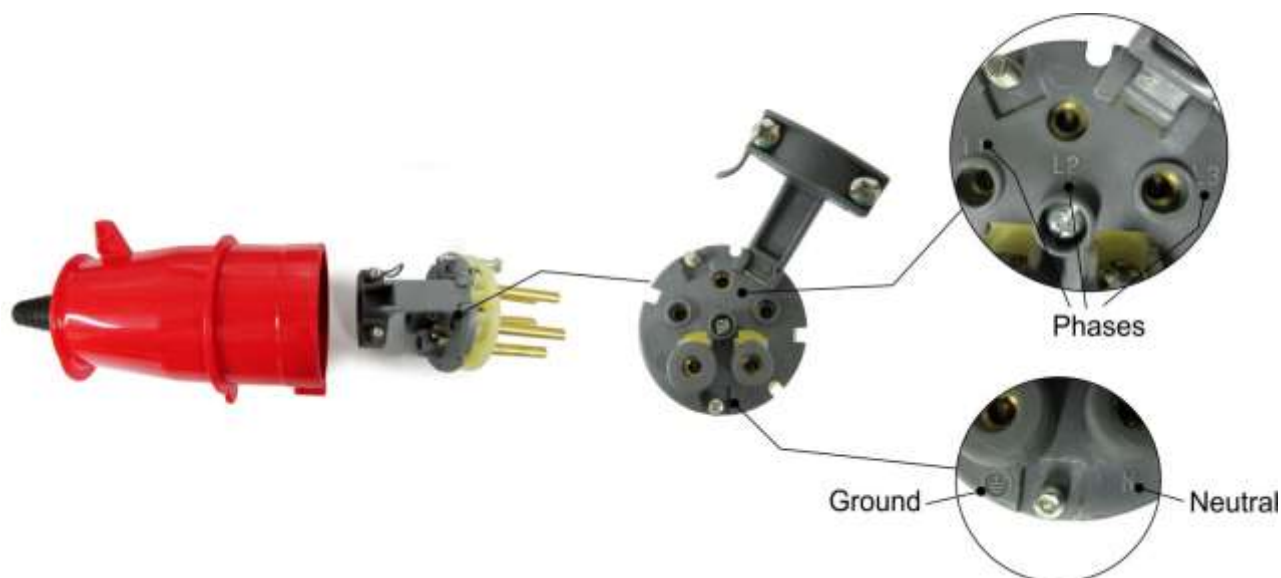

The devices described in this manual are single voltage, ie 110 V or 220 V single phase and 220 V or 380 V three phase. If voltage changes are required, contact the manufacturer or your authorized dealer.

The equipments are supplied with an equipotential grounding terminal located on the right side base on the PCI / PCL grinders.10 and 22, and in the rear base on the PCL.98.



Equipotential Switching Terminal



O borne identificado na figura ao lado, é uma proteção adicional ao aterramento que é previsto na rede elétrica, ele deve ser ligado a uma barra de terminais de aterramento, independente da ligação á rede elétrica, sendo que os demais produtos que possuam partes metálicas acessíveis, e que sejam estacionários, também devem ser ligados a este barramento bem como a própria bancada de serviços, caso esta seja de material metálico. Deste modo todos estes produtos estarão sob um mesmo potencial elétrico evitando correntes de fuga indesejáveis.



ATTENTION!

Before connecting your equipment, always check that the mains voltage is the same as the voltage of the equipment. If it is not the same, contact the manufacturer or your authorized dealer.

The supply voltage of the devices is 110 V (60 Hz) or 220 V (50 or 60 Hz) single phase and 220 V or 380 V (50 or 60 Hz) three phase (PCL.98) as shown on the voltage label attached to the power cable or as indicated on the card data label on the back of the unit (see the figure on this label in item 2.2 of this manual).

Make sure that the voltage of the mains where the equipment will be installed is compatible with the voltage indicated on these labels.

For details of the remainder of the electrical part of the equipment, refer to the wiring diagram in the manual annexes.

IMPORTANT

The manufacturer shall not be liable for any direct or indirect damages caused by non-compliance with these standards and other instructions presented in this manual.

3.3 Safety Measures and User Instruction

The professional that makes the sale of the equipment should instruct the user about the correct operation of the equipment and should give you this instruction manual.

The user must be informed of the necessary safety measures and must respect them as well as all the measures described in this manual.

Your equipment has mechanical guard (see item 1.2 Mechanical Safety). Removal or tampering with these safety components can cause serious risks to the operator's upper limbs.



ATTENTION!

It is very important, before operating your equipment, to check the direction of rotation of the endless spool or the cross blade. To do this, position yourself in front of the device and looking at the power nozzle you can see the spool or if you look at the disc you will see the crosspiece. Turn the unit on and turn it off quickly, leaving only the time required to check the direction of rotation: the spool or crosspiece must be rotating counterclockwise (pictured below), according to the direction indicated on the adhesive glued on the front the case.

For your safety, always check the direction of rotation with the spindle nozzle mounted on the bearing.

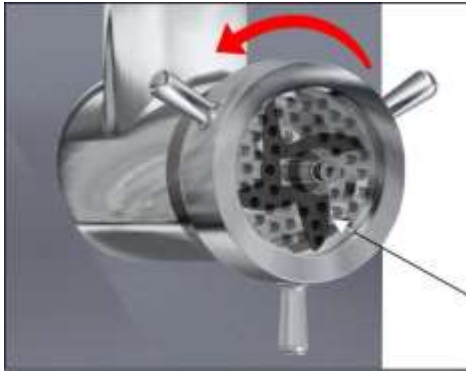

Observe if the crossblade or the endless spool is rotating counterclockwise

View the direction of rotation with the spindle nozzle and mounted disc

Cross blade (through the disk)



ATTENTION!

If they are rotating clockwise, check that the electrical connection is reversed with respect to the wiring diagram (item 9 - Attachments), refer to the electrical installation instructions in item 3.2 (Electrical Connection) or contact your nearest authorized service center from you.



ATTENTION!

Operation of the equipment in the wrong direction of rotation may lock in addition to the spool, cross blade and disc. If the equipment continues to operate in this way, there is a risk of burning the engine.

4. Equipment Usage

4.1 Utility

This equipment is exclusively intended for grinding, chopping and cutting various meats.

4.2 Commands

All equipments have the power button. When positioned in front of the grinder's mouthpiece, it is located on the left side of the equipment.

See description of the command below:

- **Power button** - used to turn the equipment on and off. In position "1" turns on, in position "0" turns off.

4.3 - Operating Procedures

Before operating your equipment, disassemble the components (the following instructions) that will come in contact with the meat (pan, socket, grinder nozzle, endless spool, cross blade, discs and nozzle nut) and clean them. Perform cleaning with the equipment disconnected from the mains. Follow the cleaning instructions in item 5 of this manual.

Check the disassembly and assembly procedures described below.

• Disassembly:

- 1 Before starting disassembly, unplug the equipment from the mains



- 2 Remove tray and socket



- 3 Rotate the knob counterclockwise to release the grinder nozzle



- 4 Pull grinder nozzle to release bearing

- 5 To disassemble the grinder nozzle, first unscrew the nut from the nozzle. The remaining pieces are removed according to the order of exploded view below:

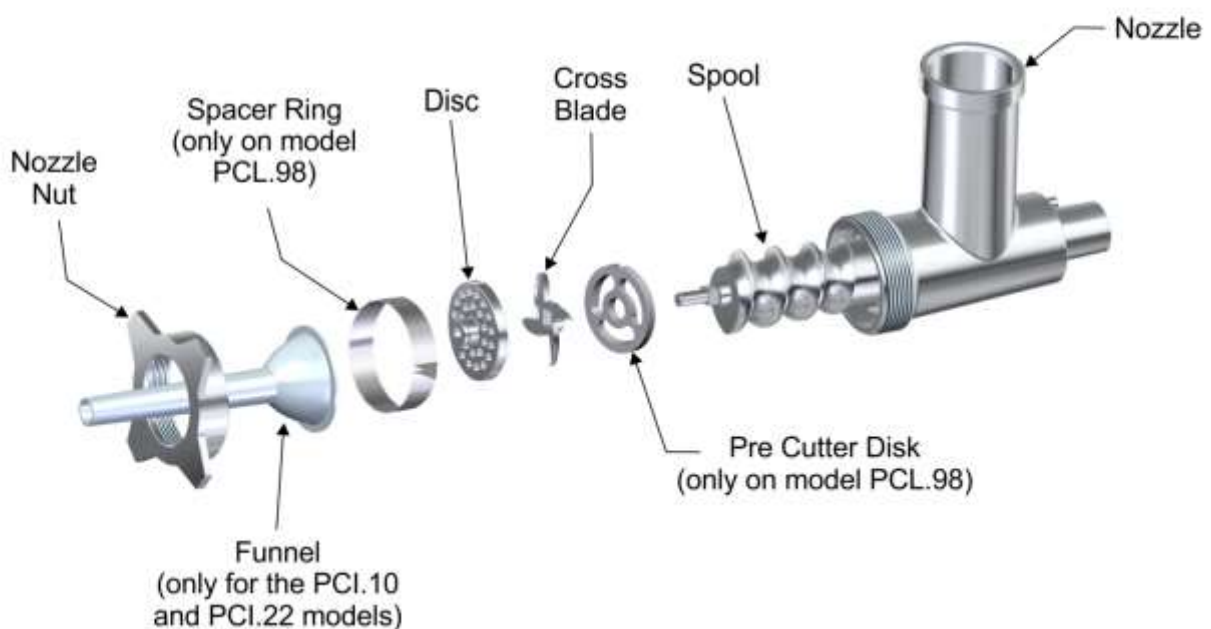

- **Assembly:** The assembly procedure is the reverse of disassembly. When attaching the crosshead blade to the spool pin, make sure the blade side of the blade is facing forward.



Mount the crossblade with the wire blade forward

Before mounting the disc, choose the model (hole \varnothing 5 or 8 mm) that fits your need at the moment. Mount the other parts of the nozzle according to the order of the exploded view (picture on the previous page).



ATTENTION!

Be careful when reassembling the nozzle nut as it can not be tightened excessively, it should simply be pressed against the end of the threading. If you squeeze excessively you will wear and force the engine, and you can burn it.

Use only the perforated discs supplied with this unit. In no case should you use discs with holes of other shapes or dimensions.

With the grinder nozzle fitted, fit it in the bearing as shown below:

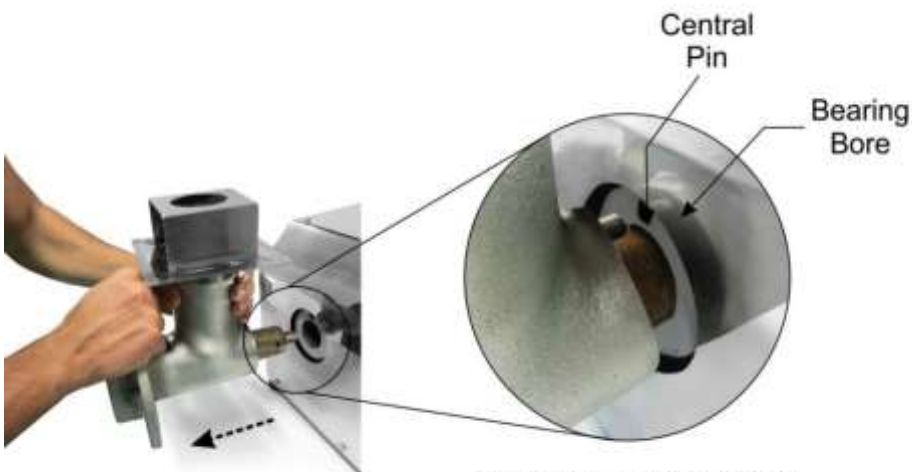

Attach the spool shaft and centering pin to the bearing



Rotate the knob clockwise to lock the grinder nozzle

All parts must be secured perfectly so that no locking or wear occurs, and to ensure operator safety. If any part has not been properly attached, repeat the operation and if do not obtain success, contact technical service.

- **Operation:** Before connecting the equipment, make sure that the endless spool is rotating correctly (counterclockwise as per instructions in 3.3), and that the supply voltage of the equipment is in accordance with the mains voltage. Also check that the tray is attached in the holder, the disc is engaged and locked with the nut of the nozzle and the nozzle of the grinder is fixed with the knob.

After verifying these items, follow the following operating procedures:

- Connect the power cord to the mains;
- Place a container to store the chopped meat below the outlet nozzle;
- If you have pre-cut pieces of meat, put them on the tray. Remove as much bones as possible, pieces of cartilage and tendons. Never use frozen meat;

Turn the power switch to "1" (on).

- Leave the equipment on for a few seconds before adding the meat;
- Direct the meat to the feed nozzle with the socket and press the meat against the endless spool;



ATTENTION!

Use only the socket to push the meat into the nozzle. Never use hands or other objects other than the socket.

- After the process is completed, switch off the equipment by pressing the power button in the "0" (off) position.



ATTENTION!

Never add meat before leaving the equipment on for a few seconds. However, do not let the equipment work for a long time without load (no meat inside the nozzle), as this leads to acceleration of wear and damage to other components.

If you notice that the machine can not process the food or that it is stopping processing, reduce the quantity or size of the pieces of meat in the pre-cut before inserting it into the feed nozzle.

Add the meat in the feed nozzle gradually so as not to impair the speed and performance of the engine, and the life of the equipment.

Never use frozen meat.

Failure to observe this guideline will be considered an unsafe act and abusive use of equipment.

Any irregularities please contact the authorized service center nearest you.



ATTENTION!

Do not remove the nozzle from the grinder or the tray with the equipment switched on, nor should your fingers, hands or objects (such as spoons and knives) be placed inside the food nozzle as this may cause accidents.

Any irregularities please contact the authorized service center nearest you.

IMPORTANT

The operator must wear the appropriate PPE (personal protective equipment). For example: use touches on the hair avoiding that they lock in the movable parts of the equipment and appropriate gloves that besides guarantee the cleanliness in the handling of the meat, protect the operator during the processing of the food.

5. Cleaning and Maintenance

5.1 Cleaning Procedures and Products Used

Your equipment is built with first-line materials, so use it correctly and you will get great satisfaction. Keep your equipment always clean and well taken care of, as this will make it have a much longer shelf life.

A daily cleaning of the machine must be carried out for good operation and durability.



ATTENTION!

Before performing maintenance or cleaning, make sure that the equipment is switched off and that the plug is disconnected from the mains.



ATTENTION!

Do not use a water jet to clean the equipment.

IMPORTANT

This equipment is not intended to be fully immersed in water for cleaning. Follow the instructions below to know the parts that can be immersed and what special care is taken with the other parts.

Dismountable parts (socket, nozzle body, endless spool, cross blade, discs and nozzle nut) must be removed from the equipment and washed with warm water and neutral soap. Clean the corners thoroughly, eliminating meat residue. Only the tray should be washed separately from other metals, avoiding damage to the material.

The remainder of the equipment should be cleaned as many times as possible to prevent food residue from drying out and sticking to parts. For cleaning, dilute soap or neutral detergent or ammonia-based remover in warm water and apply with a soft cloth. With a cloth moistened with water, rinse and then wipe the parts with a dry cloth.

TIP

The meat that remains in the equipment can be removed by slicing bread through the grinder.

It is advisable to lubricate the blade and discs with a little vegetable oil.

Never use abrasive products or sponges for cleaning as they may scratch or ruin the part surface. Do not spill water on the equipment for cleaning, otherwise, turning it on may cause electric shock or even burn the equipment.



ATTENTION!

Be careful while doing the cleaning on the cross blade as it is sharp. Knob with care as this may cause accidents. The same attention is paid to any other component of the equipment.

It is extremely important that the products used in cleaning ensure maximum cleanliness and are not toxic.

5.2 Maintenance and Behavior in Case of Breakdowns

The operator must be instructed to perform routine inspections, making minor adjustments, the cleaning and observe indications of breakdowns that may occur. Examples include: checking for extraneous noise; loss of power of the equipment; the non-performance by the equipment of the service to which it proposes; among others. Actions such as these are essential to ensure a longer equipment life.



ATTENTION!

When maintenance is made (even if small adjustments), always unplug the equipment from the mains.



ATTENTION!

Keep the discs and the cross blade always sharp, as these pieces can be sharpened when they lose the cut. To do this, contact your nearest service center.



ATTENTION!

Always check the wear of the plastic washer, located on the endless spool, replace it when necessary and never forget to attach it when assembling the nozzle, as working without this item will lead to premature wear of the parts.

It is recommended to carry out preventive maintenance every 6 months, checking and adjusting clearances, cleaning internal parts, etc. When detecting broken or weakened parts, replace with original parts.



ATTENTION!

Never let your equipment run out of oil in the gearbox as this will cause damage to your equipment. Always check the oil level.

It is recommended to change the oil every 6 months of use.

To check the quantity and type of oil used in each model, refer to the table in item 2.1 (Technical Data) of this manual.

When performing oil change, use Personal Protective Equipment (PPE) to prevent direct contact with the oil, such as waterproof PVC gloves.

Follow the instructions below to change the oil in your equipment:

- Disconnect the equipment from the mains;
- Remove the tray and nozzle from the grinder (instructions in item 4.3). Remove the case by removing the securing screws;
- Position a container under the gear case to store the oil to be removed;
- Remove the screw located under the gear case. Wait until all the oil comes out of the screw hole.
- After all the oil is removed, thread the screw with thread seal tape again;
- To install the new oil, remove the plug located on top of the gearbox;
- With the aid of a funnel, add the oil. Check the oil quantity for each grinder model in the table in item 2.2 (Technical Data);
- Screw the stopper with thread stopper. Reassemble the case by fastening it with the screws.

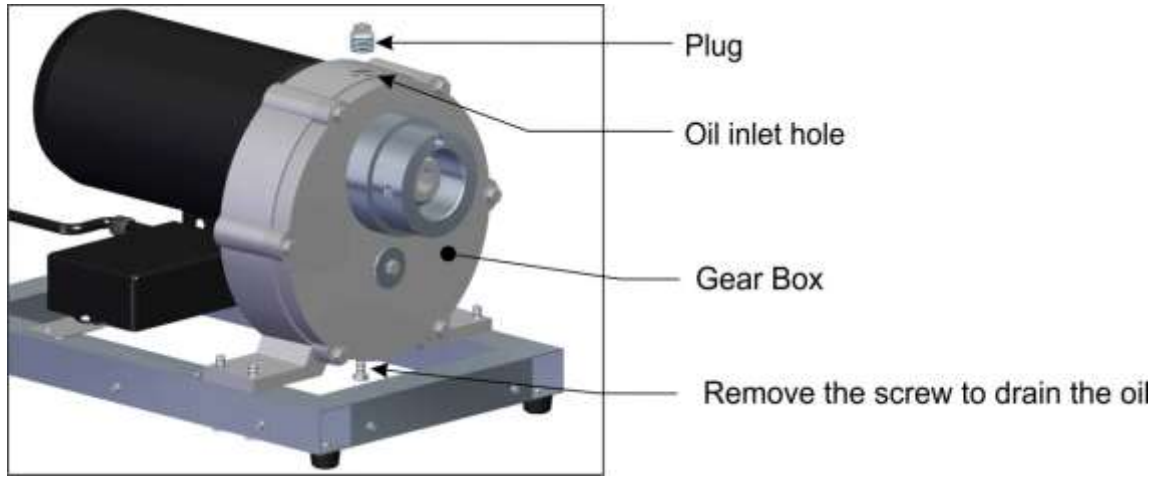

IMPORTANT

After changing the oil, the equipment must be level. Follow the instructions in item 3.1 (Device Layout) for optimal positioning of the equipment.

Oil is a recyclable product. Dispose of it at authorized service station facilities in accordance with local laws and regulations regarding the disposal of waste products. Do not empty into drains or surface water.

By performing preventive maintenance, you eliminate the inconvenience of getting the equipment stopped when you need it most, reducing the cost of maintenance and reducing the risk of accidents.



ATTENTION!

Preventive maintenance requires a trained professional.

Make sure the equipment is disconnected from the mains.

Whenever any item regarding the safety of the equipment (such as cleaning or maintenance) is removed, reset it and confirm that it is performing its function correctly.

When you experience any malfunction or non-compliance, refer your equipment to the nearest service center. See technical assistance in the folder provided with the device or consult the link on our website: www.metvisa.com.br

6. ANNEXES

Electrical Schematic - Voltage 110 V or 220 V - 60 Hz – 3/4 hp and 1 hp

Models: PCI / PCL.10/22 MF

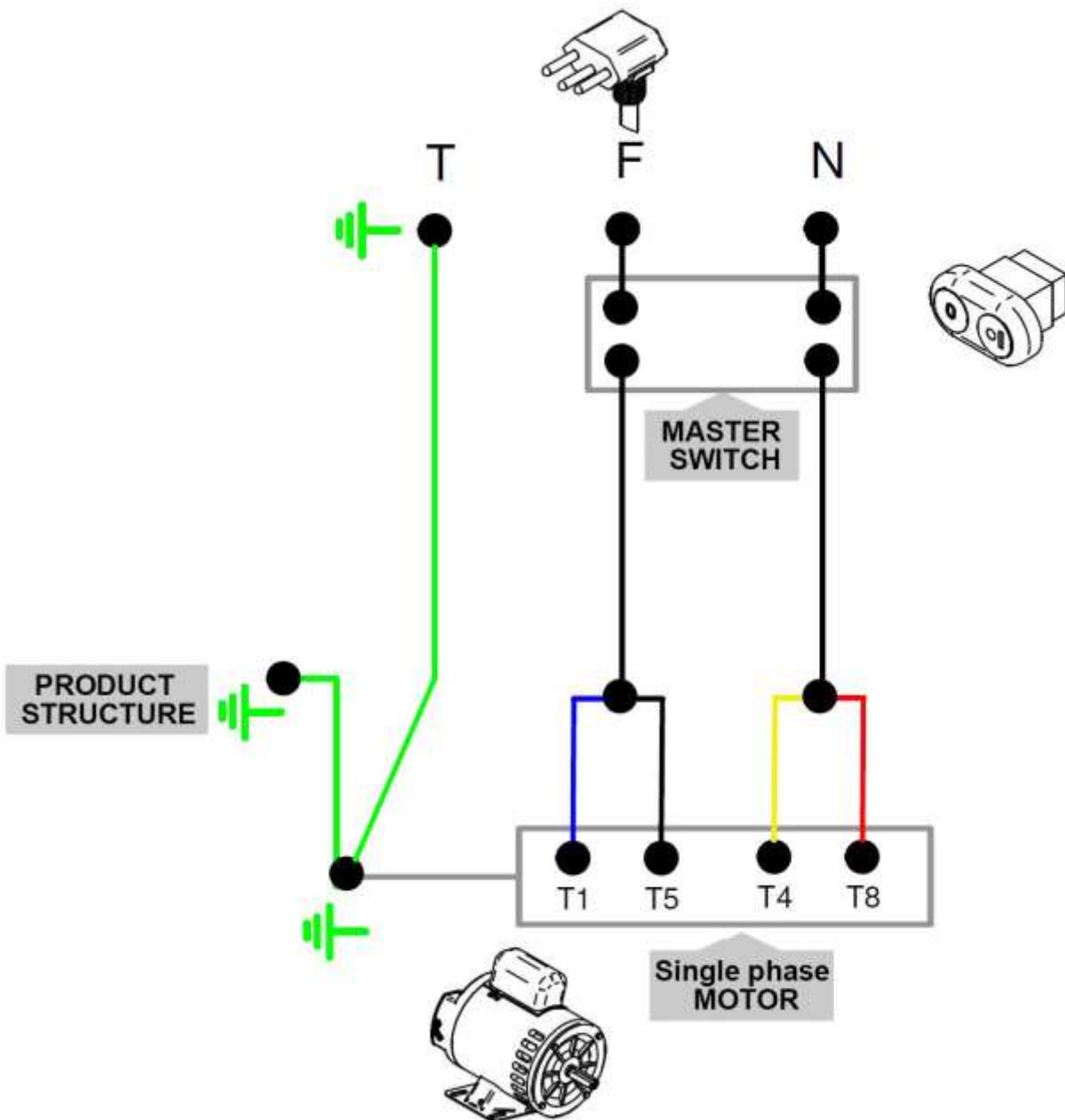

NOTE: Motor with double direction of rotation. To reverse the rotation, change T5 to T8.

Electrical Schematic - Voltage 220 V - 50 Hz – 3/4 hp and 1 hp

Models: PCI / PCL.10/22 MF

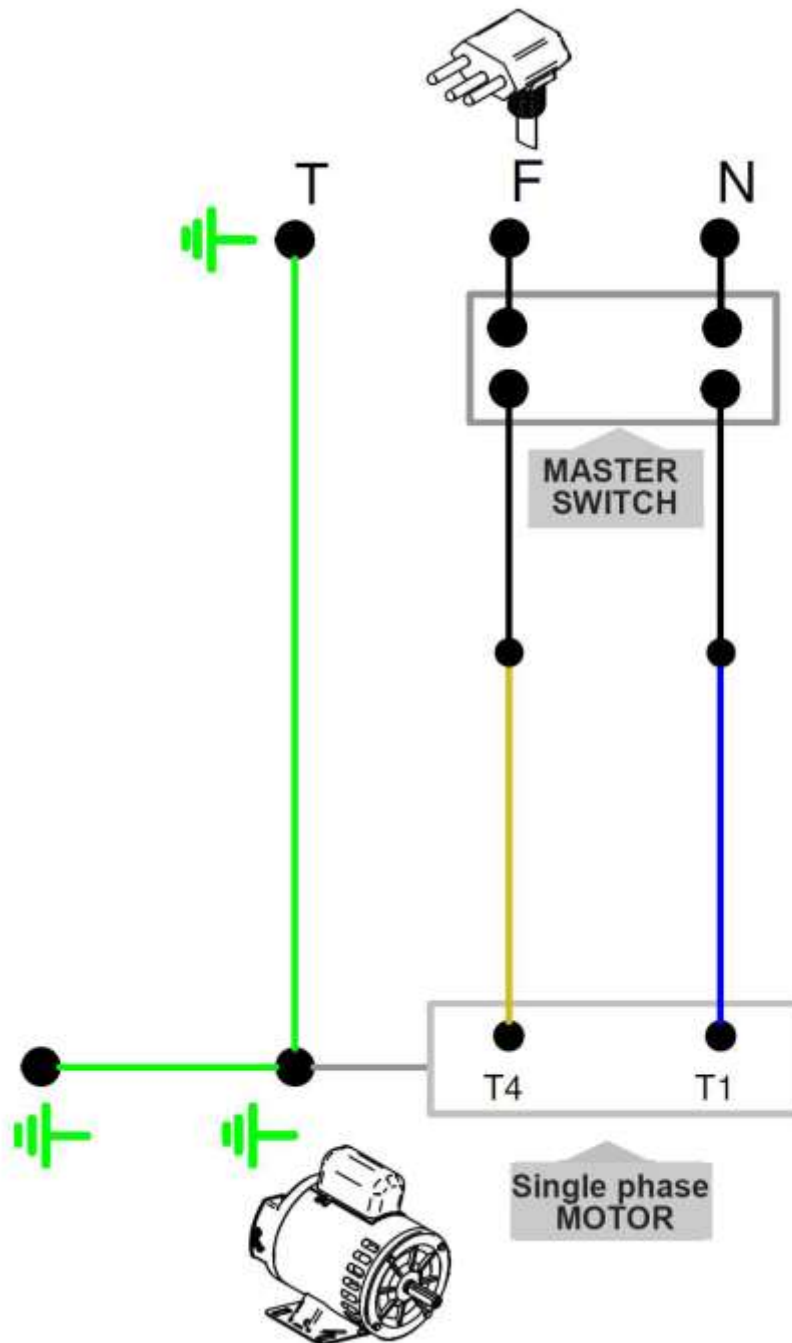

Electrical Schematic - Voltage 110 V - 60 Hz - 2 hp

Models: PCL.98 MF

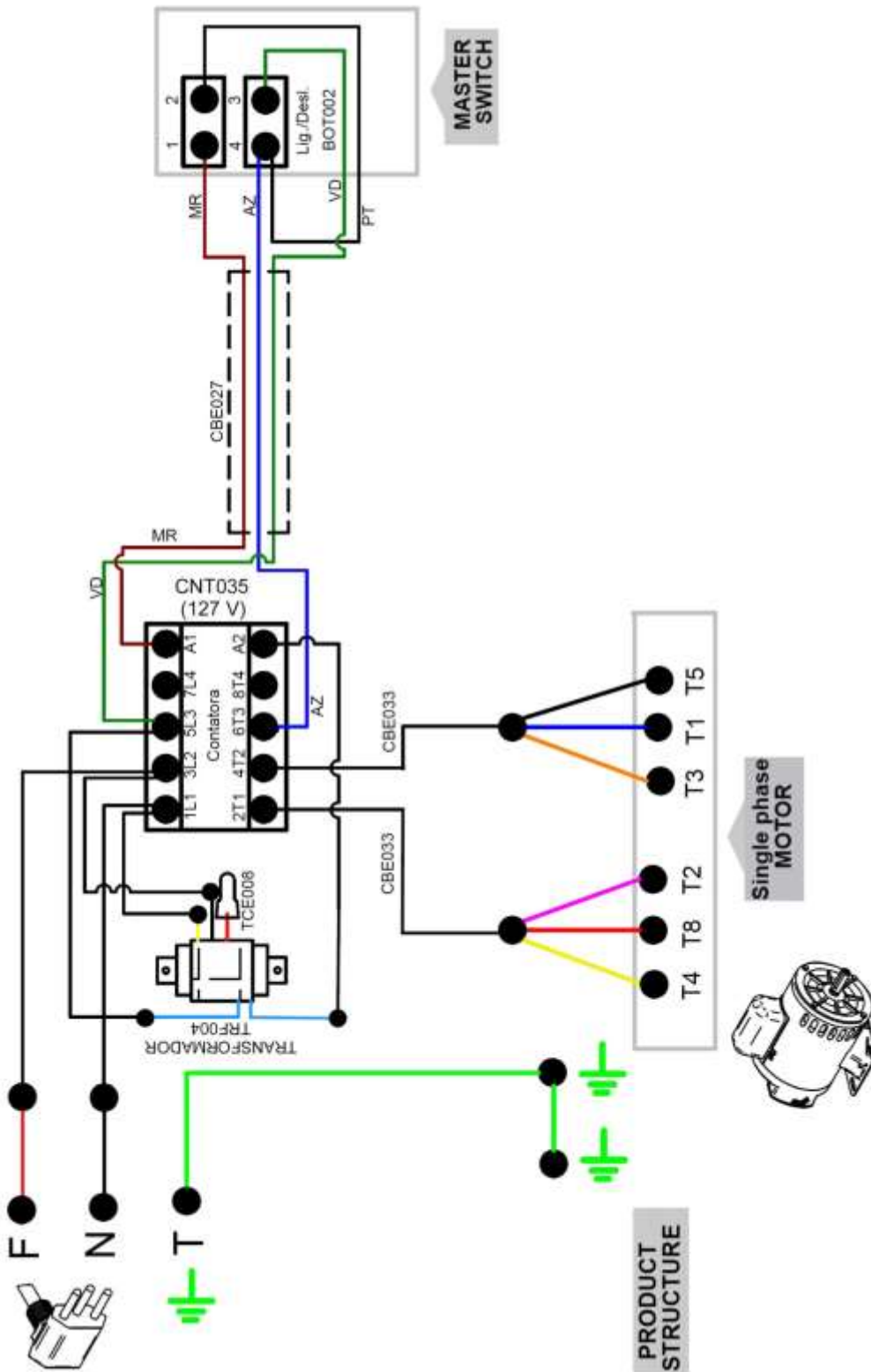

NOTE: In the above Electrical Schematic, white wires are represented by pink.
NOTE: Motor with double direction of rotation. To reverse the rotation, change T5 to T8.

Electrical Schematic - Voltage 220 V - 60 Hz - 2 hp

Models: PCL.98 MF

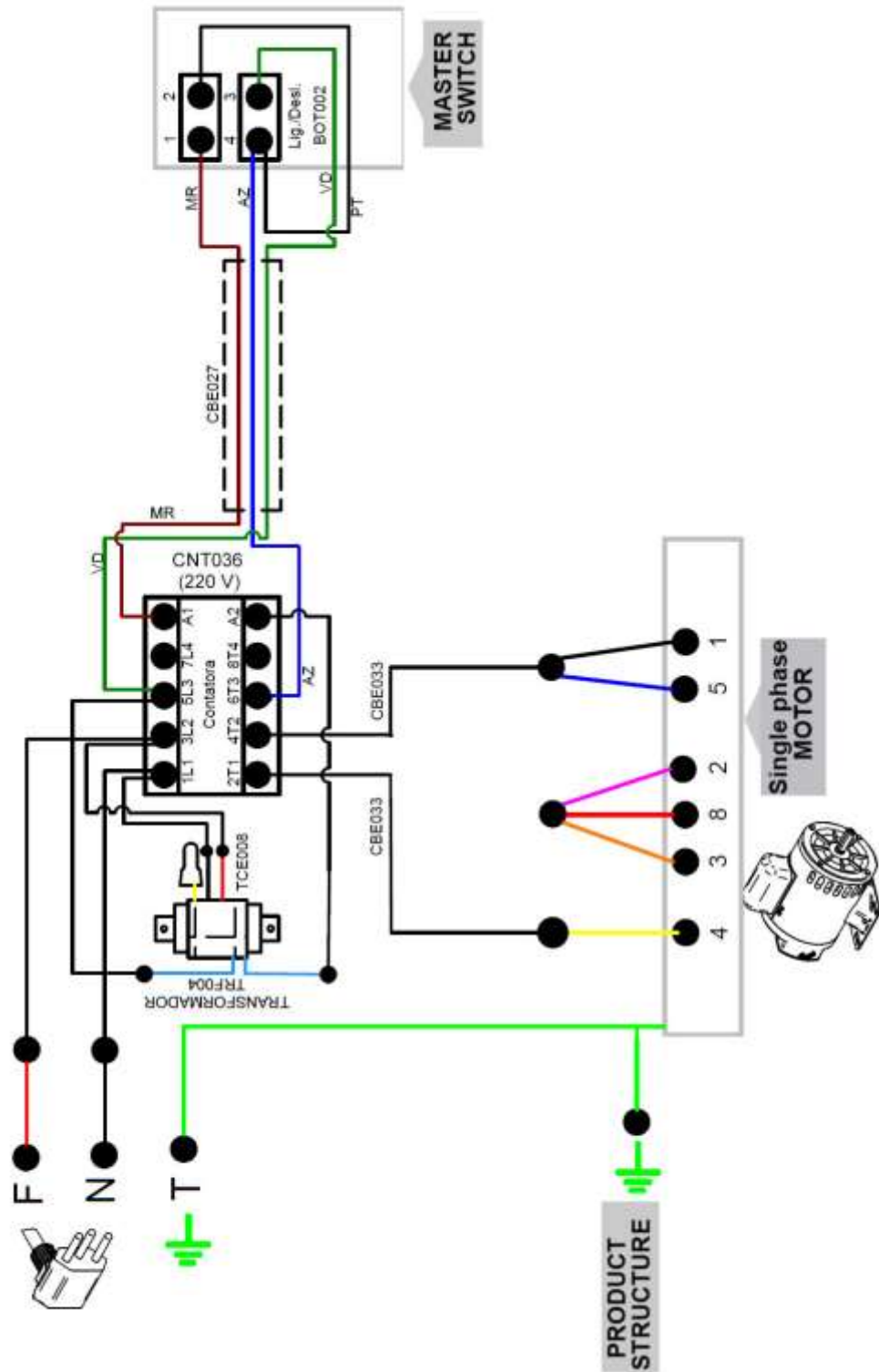

NOTE: In the above Electrical Schematic, white wires are represented by pink.
NOTE: Motor with double direction of rotation. To reverse the rotation, change T5 to T8.

Electrical Schematic - Voltage 220 V - 50 Hz - 2 hp

Models: PCL.98 MF

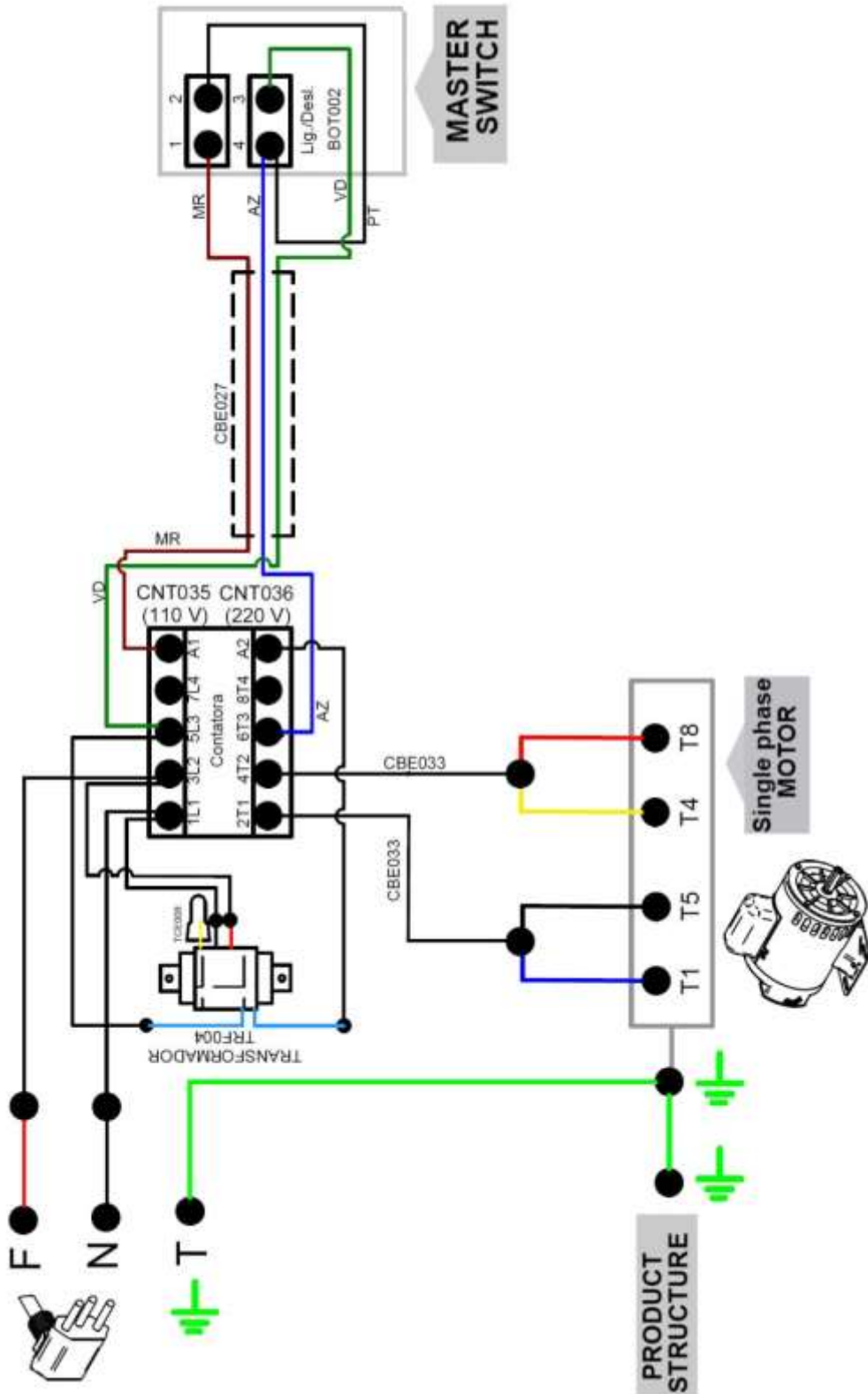

NOTE: Motor with double direction of rotation. To reverse the rotation, change T5 to T8.

Electrical Schematic - Voltage 220 V – 50 Hz or 60 Hz - 2 hp

Models: PCL.98 TF

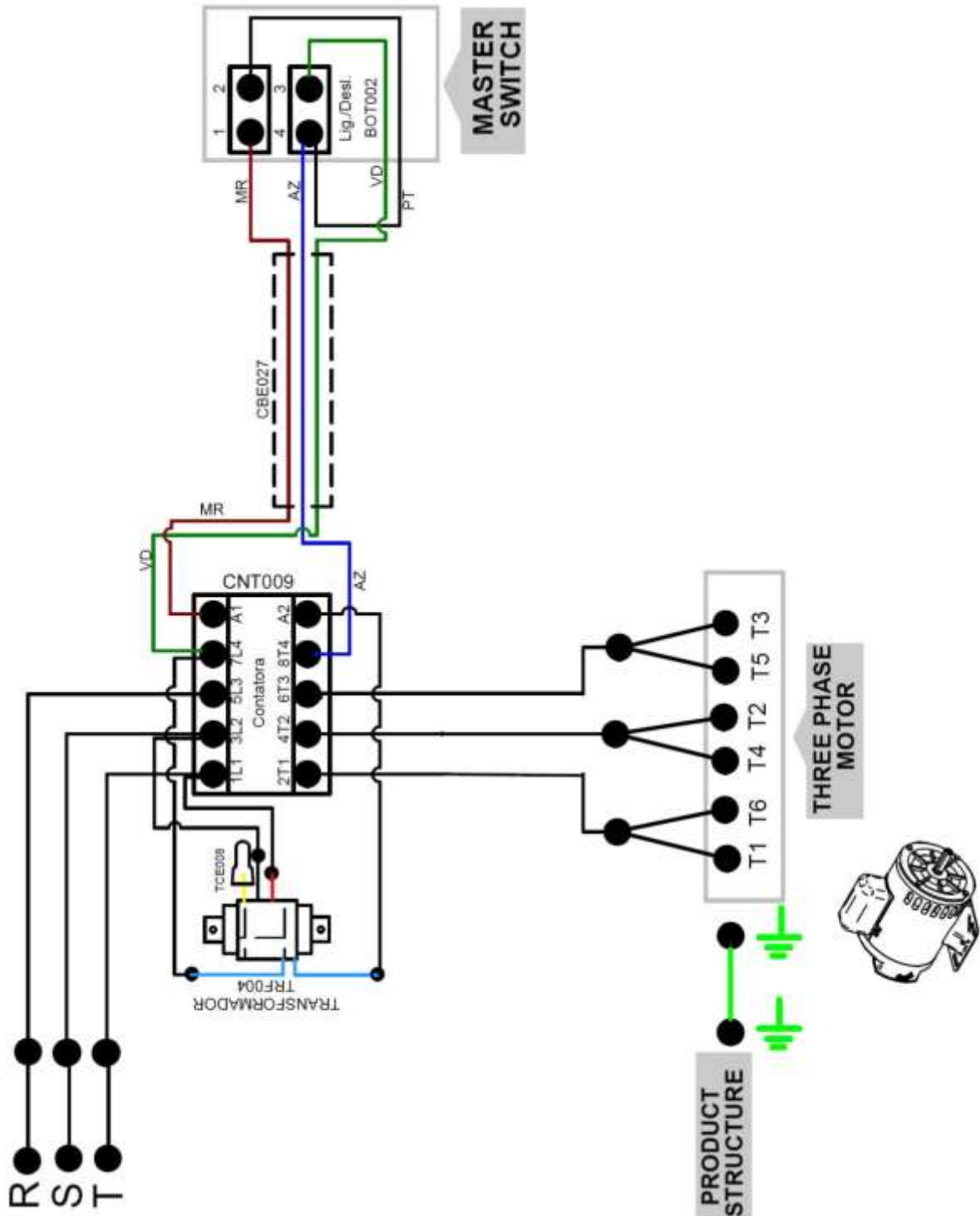

NOTE: In the above Electrical Schematic, white wires are represented by pink. To invert the rotation, change phase R through phase S.

Electrical Schematic - Voltage 380 V - 50 Hz or 60 Hz - 2 hp

Models: PCL.98 TF

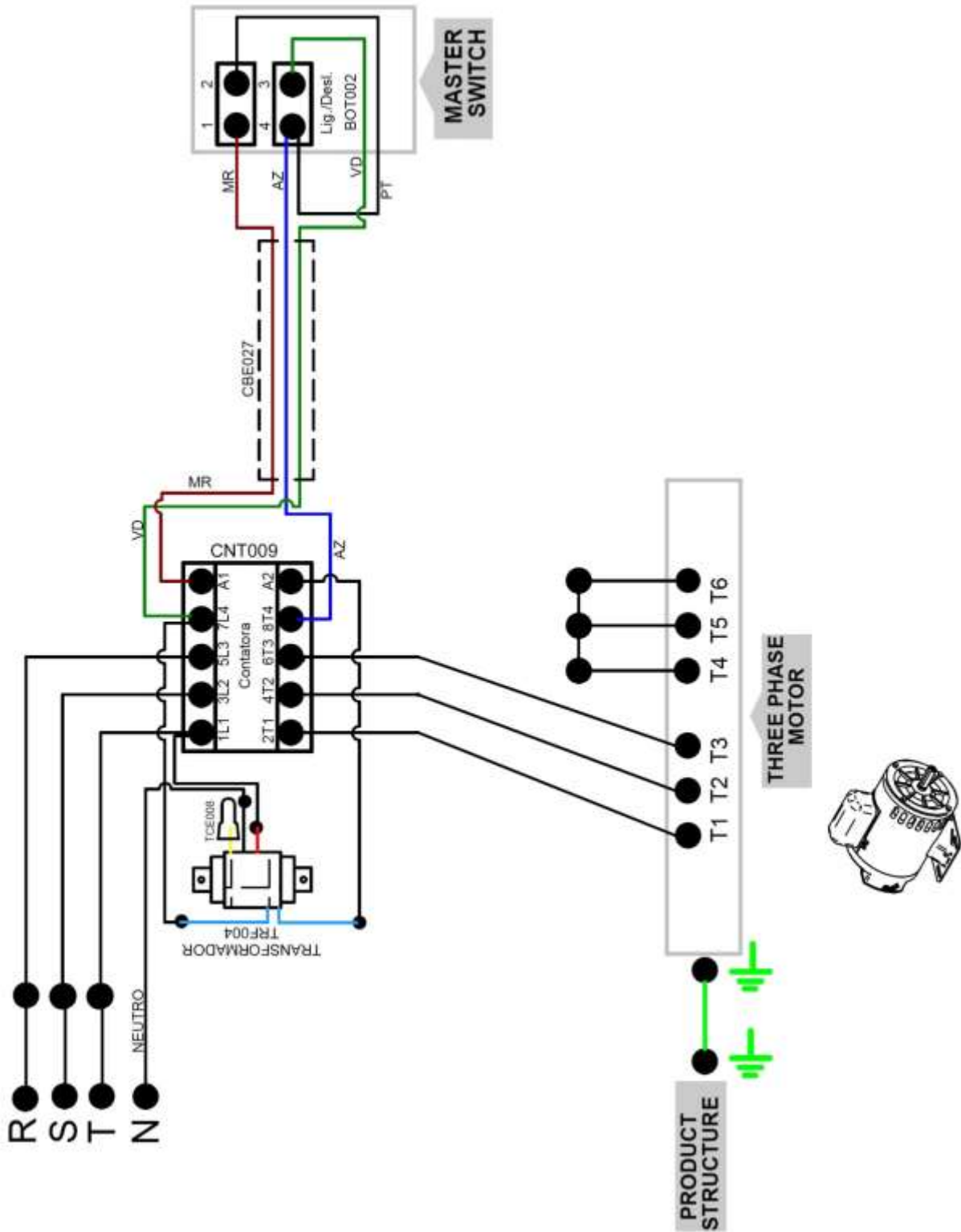

NOTE: In the above Electrical Schematic, white wires are represented by pink. To invert the rotation, change phase R through phase S.

Blown up Design

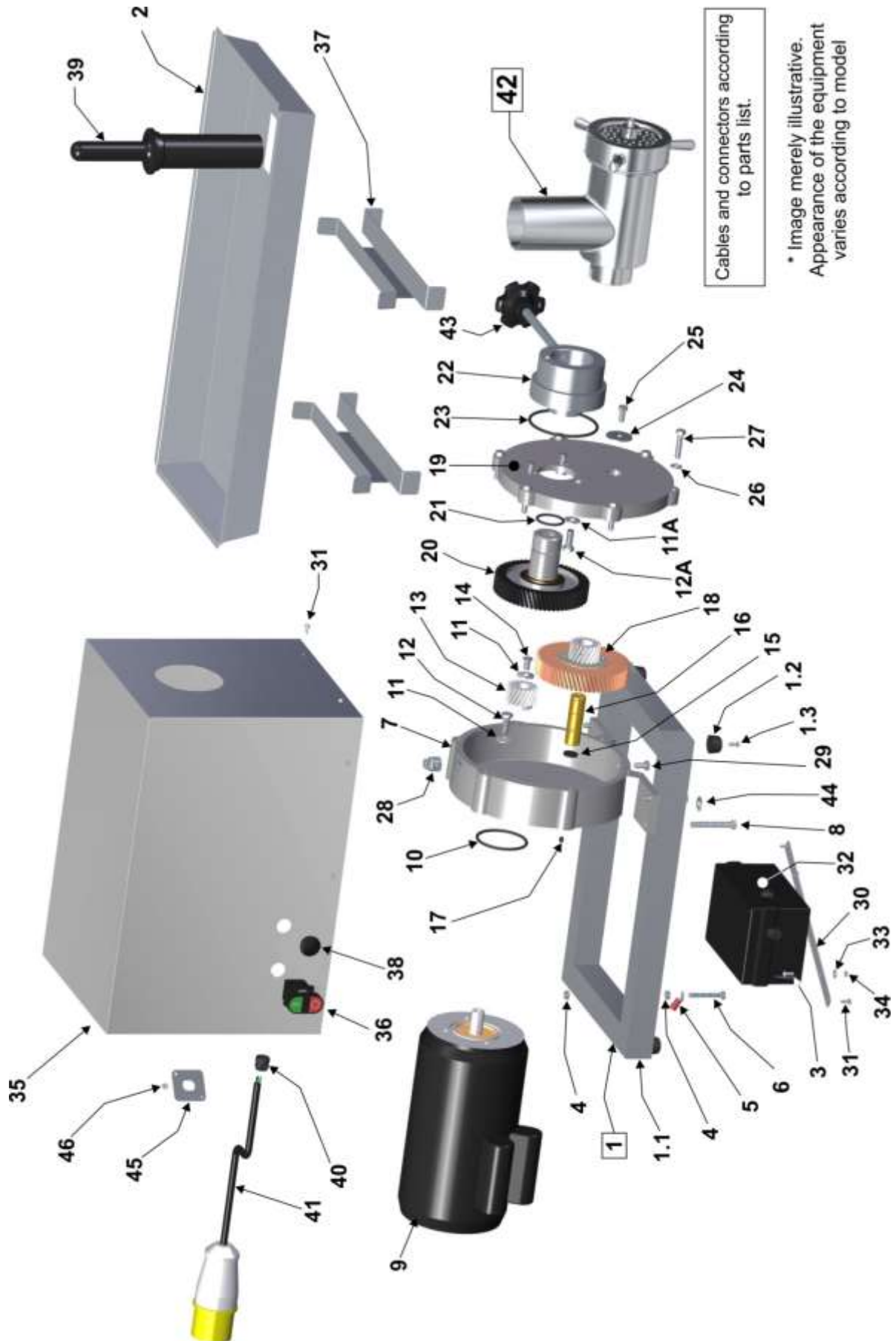

Blown up Design

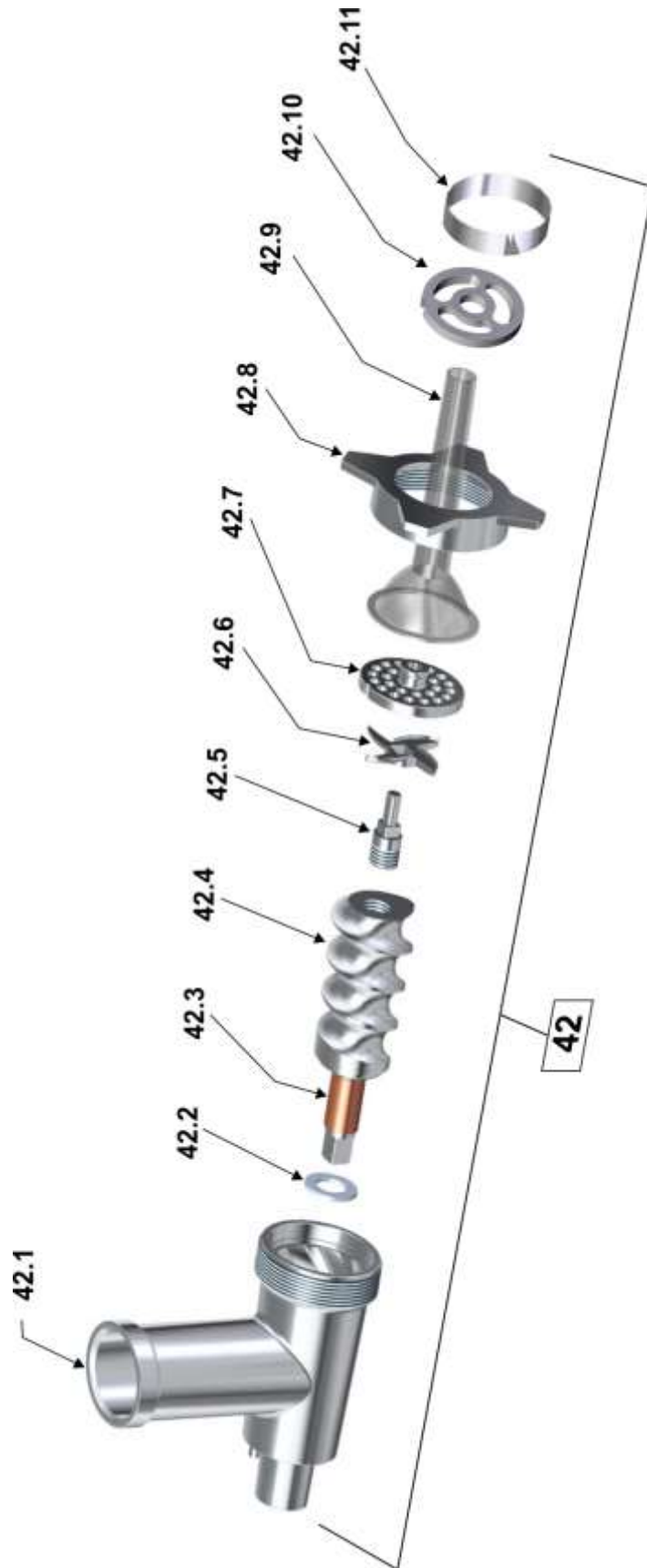

Replacement parts

Position	Code	Description	Qty.	Model
1	BAS104	Assemble Base - PCI / L.10 / 22	01	PCI/L.10/22
	CJT900	Assemble Base - PCL.98	01	PCL.98
1.1	CRC1234	Base - PCI / L.10 / 22	01	PCI/L.10/22
	BAS036	Base - PCL.98	01	PCL.98
1.2	PEP004	Rubber Foot	04	*
1.3	PRR015	Mac. Screw Round	04	*
2	BDJ041	Welded grinder Tray - PCI / L.10 / 22	01	PCI/L.10/22
	BDJ027	Welded Grinder Tray - PCL.98	01	PCL.98
3	PCC002	Screw	04	PCI/L.10/22
	PRR015	Mac. Screw Round	02	PCL.98
4	POS005	Nozzle Nut	02	PCL.98
5	TCE013	Equipotential Terminal	01	PCI/L.10/22
	TCE023		01	PCL.98
6	PRS016	Hexagonal Screw	01	PCL.98
7	CCC008	GEAR BOX	01	PCI/L.10
			01	PCI22
	CCC009	Gear box - PCL.22	01	PCL.22
	CCC010	Gear Box - PCL.98	01	PCL.98
8	PRS010	Hexagonal Screw	04	PCI/L.10/22
	PRS012		04	PCL.98
9	MTE232	Electric Motor. MF 3/4 hp 110 V 60 Hz	01	PCI/L.10
	MTE233	Electric Motor. MF 3/4 hp 220 V 60 Hz		
	MTE113	Electric Motor. MF 3/4 hp 220 V 50 Hz		
	MTE234	Electric Motor. MF 1 hp 110 V 60 Hz	01	PCI/L.22
	MTE235	Electric Motor. MF 1 hp 220 V 60 Hz		
	MTE114	Electric Motor. MF 1 hp 220 V 50 Hz		
	MTE112	Electric Motor. MF 2 hp 110/220 V 60 Hz	01	PCL.98
	MTE042	Electric Motor. MF 2 hp 220 V 50 Hz	01	PCI/L.98 TF
	MTE013	Electric Motor. TF 2 hp 220/380 V 60 Hz		
MTE043	Electric Motor. TF 2 hp 220/380 V 50 Hz			
10	ORG010	O'ring Engine	01	*
11	ARL004	Flat washer	01	PCI/L.10/22
	ARL002		01	PCL.98
11A	ARL007	Flat washer	04	PCI/L.10/22
	ARL002		03	PCL.98
12	PRS003	Hexagonal Screw	02	PCI/L.10/22
			03	PCL.98
12A	PRS006	Hexagonal Screw	03	PCI/L.10/22
	PRS003		03	PCL.98
13	EGG052	Helical Motor Gear - PCI / L.10 / 22	01	PCI/L.10/22
	EGG059	Helical Motor Gear - PCI/L.98	01	PCL.98
14	PCC003	Cylindrical Screw Machine	01	PCI/L.10/22
	PRC004	Machine Flathead Screw	01	PCL.98
15	BCH069	Rubber Seal Oil cap - PCI / L.10 / 22	01	PCI/L.10/22
	BCH070	Rubber Seal Oil cap - PCI/L.98	01	PCL.98
16	EIX124	Brass Intermediate Shaft	01	PCI/L.10
			01	PCI22
	EIX126	Brass Intermediate Shaft-PCL.22	01	PCL.22
	EIX127	Intermediate Brass Shaft - PCL.98	01	PCL.98
17	PRN004	Allen screw	02	PCL.98
18	EGG054	Helical Fiber Gear	01	PCI/L.10
				PCI22
	EGG058	Helical Gear Fiber - PCL.22	01	PCL.22
	EGG060	Helical Fiber Gear - PCL.98	01	PCL.98

* Item applicable to all models of Meat grinders.

Replacement parts

Position	Code	Description	Qty.	Model
19	TAP140	Gear Box Cover	01	PCI/L.10 PCI22
	TAP062	Gear Box Cover - PCL.22	01	PCL.22
	TAP063	Gear Box Cover - PCL.98	01	PCL.98
20	EGG055	Helical Iron Gear	01	PCI/L.10 PCI22
	EGG057	Iron Helical Gear - PCL.22	01	PCL.22
	EGG061	Iron Helical Gear - PCL.98	01	PCL.98
21	ORG002	O-Ring	01	PCI/L.10 PCI.22
	ORG019	O'ring - PCL.22	01	PCL.22
	ORG004	O'ring - PCL.98	01	PCL.98
22	MAC079	Bearing - PCI.10/22	01	PCI10/22
	MAC065	Bearing - PCL.10	01	PCL.10
	MAC066	Bearing - PCL.22	01	PCL.22
	MAC067	Bearing - PCL.98	01	PCL.98
23	ORG011	O'ring Motor - PCI / L.10 / 22	01	PCI/L.10/22
	ORG018	O'ring Motor - PCL.98	01	PCL.98
24	ARE001	Flat washer	01	PCL.98
25	PRS007	Hexagonal Screw	01	PCL.98
26	ARL004	Flat washer	04	PCI/L.10/22
	ARL007	Flat washer	06	PCL.98
27	PRS004	Hexagonal Screw	04	PCI/L.10 PCI22
	PRS037	Hexagonal Screw	04	PCL.22
	PRS009	Hexagonal Screw	06	PCL.98
28	BUJ005	End plug	01	*
29	PRS008	Hexagonal Screw	01	*
30	SBT122	Capacitor Mounting Bracket	01	PCI/L.10/22
	SBT450		01	PCL.98
31	PRA014	Locking Screw. Hex Stainless Steel Rod	10	PCI10/22
	PRA008	Locking Screw. Hex. Brocante	10	PCL.10/22
			12	PCL.98
32	CHE132	Electronic Board - 127/220 V MF 1cv	01	PCI/L.10/22
	CJE175	Electronic Board - 110 V MF 3 cv	01	PCL.98 127V MF
	CJE176	Electronic Board - 220 V MF 3 cv	01	PCL.98 220V MF
	CHE177	Electronic Board - 220/380 V TF 3 cv	01	PCL.98 TF
33	ARL008	Flat Washer	02	PCL.98
34	POS006	Nozzle Nut	02	PCL.98
35	GAB156	Welded Case	01	PCI/L.10 PCI22
	GAB157	Welded Case - PCL.22	01	PCL.22
	GAB192	Welded Case - PCL.98	01	PCL.98
36	CHE064	Power Button	01	PCI/L.10/22
	BOT002		01	PCL.98
37	SBT321	PCI Tray Support10	02	PCI10
	SBT323	PCL Tray Support10		PCL.10
	SBT322	PCI Tray Support22	02	PCI22
	SBT324	PCL Tray Support22	02	PCL.22
	SBT334	PCL Tray Support98	01	PCL.98
38	BCH036	Round Cap	01	*
39	SQT025	Socket - PC.10	01	PCI/L.10
	SQT002	Socket - PC.22/98	01	PCI/L.22/98
40	TCE021	Minor Press cable	01	PCI/L.10/22 220 V
	TCE022	Major Press cable	01	PCI/L.10/22 110 V PCL.98

* Item applicable to all models of Meat grinders.

Replacement parts

Position	Code	Description	Qty.	Model
41	CBE001	Electrical Cable 3x1.0 Type 4	01	PCI/L.10/22 220 V
	CBE007	Electrical Cable 3x1.0 Type 2	01	PCI/L.10/22 220 V
	CBE020	Electrical Cable 2x1.0 Type 1	01	PCI/L.10/22 220 V
	CBE002	Electrical Cable 3x1.5 - Type 4	01	PCI/L.10 110 V
	CBE003	Electrical Cable 3x2.5 - Type 4	01	PCI/L.22 110 V
	CBE209	Flexible Cable 3x2.5mm with Plug 2P + T - 110 V	01	PCI/L.98 110 MF
	CBE131	Flexible Cable 3x1.5mm with Plug 2P + T - 220 V	01	PCI/L.98 220 MF
	CBE204	Flexible Cable 5x1mm with Plug 3P + N + T - 220V	01	PCI/L.98 220 TF
	CBE203	Flexible Cable 5x1mm com Plug 3P+N+T - 380V	01	PCI/L.98 380 TF
42	CJT356	Complete Head Nozzle - PC.10	01	PCI10
	CJT038			PCL.10
	CJT358	Complete Head Nozzle - PC.22	01	PCI22
	CJT037			PCL.22
	CJT648	Complete Head Nozzle - PC.98	01	PCL98
42.1	BCA014	Body of the Nozzle - PC.10	01	PCI10
	BCA003			PCL.10
	BCA015	Body of the Nozzle - PC.22	01	PCI22
	BCA002			PCL.22
	BCA001	Body of the Nozzle - PC.98	01	PCL.98
42.2	ARE026	Plastic Washer - PC.10	01	PCI10
	ARE009			PCL.10
	ARE027	Plastic Washer - PC.22	01	PCI22
	ARE010			PCL.22
		Plastic Washer - PC.98	01	PCL.98
42.3	BGT035	Bushing - PCI.10	01	PCI10
	BGT036	Bushing - PCI.22	01	PCI22
42.4	SFC006	Spool- PC.10	01	PCI10
	SFC001			PCL.10
	SFC005	Spool- PC.22	01	PCI22
	SFC002			PCL.22
	SFC009	Spool- PC.98	01	PCL.8
42.5	EIX138	Spool Pin - PC.10	01	PCI10
	EIX086			PCL.10
	EIX140	Spool Pin - PC.22	01	PCI22
	EIX087			PCL.22
	EIX195	Spool Pin - PC.98	01	PCL98
42.6	FAC008	Cross blade - PC.10	01	PCI10
	FAC003			PCL.10
	FAC009	Cross blade - PC.22	01	PCI22
	FAC002			PCL.22
	FAC011	Cross blade - PC.98	01	PCL98
42.7	DIS049	Disc Ø 5 mm - PCI.10	01	PCI10
	DIS050	Disc Ø 8 mm - PCI.10		PCI10
	DIS004	Disc Ø 5 mm - PCL.10	01	PCL.10
	DIS005	Disc Ø 8 mm - PCL.10		PCL.10
	DIS051	Disc Ø 5 mm - PCI.22	01	PCI22
	DIS052	Disc Ø 8 mm - PCI.22		PCI22
	DIS006	Disc Ø 5 mm - PCL.22	01	PCL.22
	DIS007	Disc Ø 8 mm - PCL.22		PCL.22
	DIS008	Disc Ø 5 mm - PCL.98	01	PCL.98
DIS009	Disc Ø 8 mm - PCL.98	PCL.98		
42.8	POE016	Nozzle Nut-PC10	01	PCI10
	POE003			PCL.10
	POE017	Nozzle Nut-PC22	01	PCI22
	POE004			PCL.22
	POE018	Nozzle Nut-PC98	01	PCI98
POE005	PCL.98			
42.9	FNL003	Plastic Funnel - PCI.10	01	PCI10
	FNL004	Plastic Funnel - PCI.22	01	PCI22
42.10	DIS063	Disc pre Cutter	01	PCL.98
42.11	ANL016	Spacer Ring – PCL.98	01	PCL.98

Replacement parts

Position	Code	Description	Qty.	Model
43	MNL047	Stainless steel Knob	01	PCI10/22
	MNL004	Knob	01	PCL.10/22
	MNL001	Knob	01	PCL.98
44	ARL004	Flat washer	04	PCI/L.10/22
45	SBT360	Minor Cable Press Support	01	PCI/L.10/22- 220
	SBT361	Major Cable Press Support	01	PCI/L.10/22 – 110
46	RBT003	Rivet	02	PCI/L.10/22
47	CBE100	Cable Splicing	02	PCI/L.10/22
48	CBE104	Cable Splicing	01	PCI/L.10/22
49	CBE162	Electrical Cable Splicing	01	PCL.98
50	TCE004	Terminal Fit	01	PCI/L.10/22
			02	PCL.98
51	TCE013	Terminal	02	PCI/L.10/22
			04	PCL.98
52	TCE033	Orange Threaded Connector	09	PCI/L.10/22
			05	PCL.98

* Item applicable to all models of Meat grinders.

IMG BRASIL PRODUCT MANUFACTURER

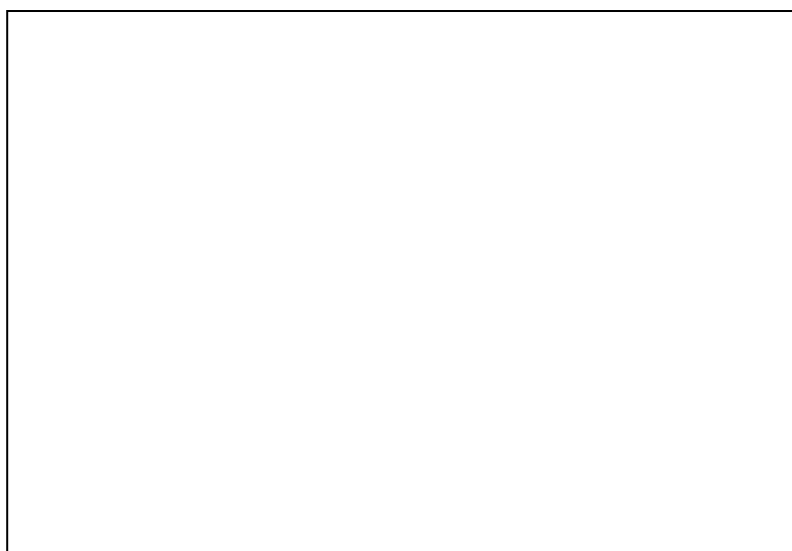

IMG-BRASIL Indústria de Máquinas para Gastronomia Ltda.

CNPJ 11.193.347/0001-14 - CREA 131726-3
Rod. Antônio Heil - KM 23 Nº 5825 - Bairro: Limoeiro
ZIP CODE 88352-502 - Brusque - SC - Brazil
Phone/fax. +55 47 3251-5555 - Website: www.metvisa.com.br
E-mail: sac@metvisa.com.br - vendas@metvisa.com.br

Other ManualsLib Projects



www.manualslib.com



www.manualslib.de



www.manualslib.es



www.manualslib.fr



www.manualslib.nl



www.manualslib.mx



www.manualslib.tech 30+ Languages